

**5500**



## ■ The Company

### Production, R+D+i, evolution.



VALVULAS NACIONAL, S.A. was established in Spain in 1976. The main target was to assist the petrochemical and chemical industries emerging in Spain at that time. Right from the start VALVULAS NACIONAL, S.A., has been designing and producing safety valves according to most recognized international standards and norms: API, ASME, ASTM and the European directives 97/23 & 94/9 CE. Our production process is accredited by an ISO 9001-2008 certification.



Our know how and capacity to adapt to the constantly changing demands of the market, made possible the introduction of new products designed for new applications in the market, like THERMOSOLAR PLANTS, where VALVULAS NACIONAL has supplied safety valves to more than 16 complete plants all over the world, while at the same time continuously supplying to all the main players in the Spanish petrochemical, chemical and refining industries.

### Production capacity.



VALVULAS NACIONAL, S.A. valves' have their discharge coefficients approved in laboratory tests, in order to guarantee and assure the correct values are being used for every sizing process.

In our Technical sales department we work with a modern software which allows us to verify all the possibilities, and to assure strict fulfillment of all international standards.

VALVULAS NACIONAL, S.A. has established representation agreements with the most important O.E.M. companies in the safety sector of the industry, consolidating us as one of the main companies by product range; design and consulting in new plants or in new process.

Our continuous growth, shows a clear trend, which confirms the integration of our workers to provide first class service to our customers and partners.

### Factory & location.



Our facilities are Rubí (Barcelona - Spain), with more than 1.200 m2 are fully prepared for our production activities: machining with modern CNC, assembling and testing. We also have long term agreements with approved workshops, which provides us with flexibility and fast feedback to customers demands, with full quality guarantee which has always been our main target.

### Strategic alliances.

Nowadays VALVULAS NACIONAL, S.A. starts an internationalization process, establishing representation agreements in different countries and continents all over the world, with specialized companies that will provide added value in our service towards the end user.

VALVULAS NACIONAL providing safety since 1976 !

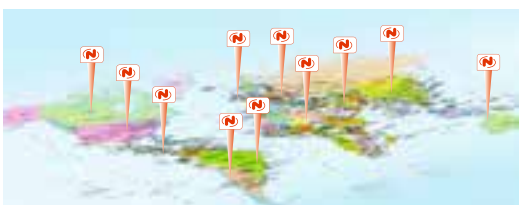

■ **Index**

• GENERAL FEATURES	<b>4</b>
• CODIFICATION SYSTEM	<b>5</b>
• PART LIST	<b>6</b>
• BILL OF MATERIALS	<b>7</b>
• ACCESSORIES	<b>8</b>
• GENERAL DIMENSIONS	<b>9</b>
• SAFETY VALVE MAIN COMPONENTS	<b>10</b>
• TECHNICAL INFORMATION	<b>10</b>
OPERATING CHARACTERISTICS TABLE	<b>10</b>
GASES DISCHARGE FLOW	<b>11</b>
STEAM DISCHARGE FLOW	<b>12</b>
LIQUIDS DISCHARGE FLOW	<b>13</b>
• DEFINITIONS (EN ISO 4126-1)	<b>14</b>

## ■ General features

The model 5500, is an angular type safety valve at 90° between the inlet and the outlet connections, with flanged connections, semi nozzle, direct action and spring loaded. It is designed with the same trims to work with gases and vapours or liquids.

### DESIGN

- Valve body is angular type at 90° between inlet and outlet flanges.
- Simplicity of construction, resulting in a valve with high reliability and easy maintenance.
- Self-aligning disc system with guide separated from the valve body, resulting an excellent tightness after valve opening.
- Springs are designed using a tested and highly reliable calculation software and manufactured with the ideal material qualities for the process conditions, ensuring elasticity and accurate repetition of valve opening.

### CODES AND STANDARDS

Valves have been designed and manufactured in compliance with the following directives, codes and standards:

European Directive:	97/23/CE (PED)
European Directive:	94/9/CE (ATEX)
Design:	EN ISO 4126-1/ASME VIII DIV.1 / AD 2000-Merkblatt A2
Certifications:	PED MODULE B+D / AD 2000-Merkblatt A2
Pressure and Temperature Limits:	EN 1092-1 & ASME B16.34
Tests:	API-527 & ASME B16.34
Quality system:	EN ISO 9001:2008
Materials:	EN & ASTM/ASME

### SIZES AND RATINGS

Standard sizes and ratings:

ASME:	
Sizes:	¾"x1¼" up to 6"x10"
Rating:	150# up to 300#
EN/ISO:	
Sizes:	DN-20xDN-32 up to DN-150xDN-250
Rating:	PN-16 up to PN-40

- This catalogue reflects standard valves. Upon request, our technical department can design special applications.
- The safety valve is an automatic direct acting accessory whose function is to relieve excessive overpressures for the applications and installations it protects. Its main characteristics, allow sudden fluid discharge with complete and fast opening (pop).
- Automatic valve opening is produced by of the additional lift provided by the overpressure of the fluid itself helping to overcome spring resistance. Once the installation has recovered its normal service condition, the valve closes again.

### INSTALLATION

Cleanliness in installation is essential for a successful valve operation. Remove all foreign materials and if possible blow away pipelines and connections on the inlet side of the valve.

Mount the valve in a vertical upright position and keep inlet and discharge piping as short as possible. No stop valves may be located between the vessel protected and its pressure relief device, and the inlet piping shall have at least the passage area of the safety valve.

The discharge pipe size will never be less than valve outlet, and a drain should be provided to avoid condensate accumulation.

Prevent strain on valve body and outlet flange by supporting the discharge piping.

### NAMEPLATE EN ISO 4126-1



## ■ Codification system

<b>55</b>	<b>A</b>	<b>B</b>	<b>1</b>	<b>1</b>	<b>A</b>	<b>-</b>
1 <sup>st</sup>	2 <sup>nd</sup>	3 <sup>rd</sup>	4 <sup>th</sup>	5 <sup>th</sup>	6 <sup>th</sup>	7 <sup>th</sup>

- 1<sup>st</sup> DIGIT: Valve model**
- 2<sup>nd</sup> DIGIT: Inlet nominal size**
- |          |           |
|----------|-----------|
| A: DN 20 | G: DN 80  |
| B: DN 25 | H: DN 100 |
| C: DN 32 | I: DN 125 |
| D: DN 40 | J: DN 150 |
| E: DN 50 | K: DN 200 |
| F: DN 65 | L: DN 250 |
- 3<sup>rd</sup> DIGIT: Outlet nominal size**
- (Same 2nd Digit)
- 4<sup>th</sup> DIGIT: Inlet rating**
- 1: PN 16
  - 2: PN 25
  - 3: PN 40
  - 4: 150 #
  - 5: 300 #
  - X: OTHERS
- 5<sup>th</sup> DIGIT: Outlet rating**
- (Same 4th Digit)
- 6<sup>th</sup> DIGIT: Material**
- 7<sup>th</sup> DIGIT: Standards accessories**

<b>X0</b>	Packed Lever
<b>X1</b>	Test Gag
<b>X2</b>	Packed lever + Test Gag
<b>X3</b>	Open Bonnet
<b>X4</b>	Open Bonnet + Test Gag
<b>X5</b>	Open Bonnet + Test Gag + Packed Lever
<b>Y4</b>	Plain Lever
<b>Y5</b>	Plain Lever + Test Gag
<b>Z4</b>	Inconel X-750 Spring
<b>W1</b>	Open bonnet + Packed lever
<b>W4</b>	Nozzle with "Stellite"
<b>W5</b>	Disc with "Stellite"

■ **Part list**

**CONVENTIONAL VALVE**

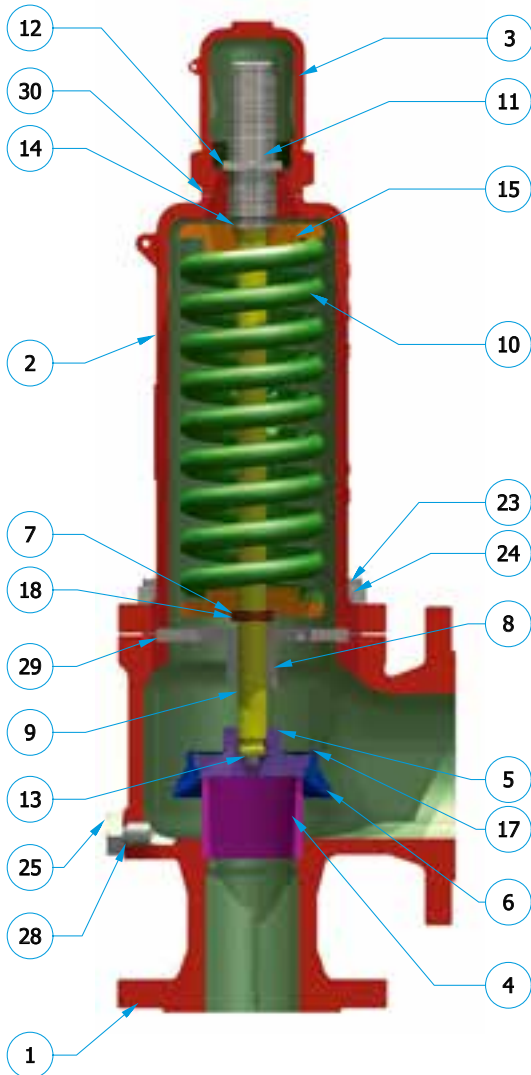

**PLAIN LEVER**



**PACKED LEVER**

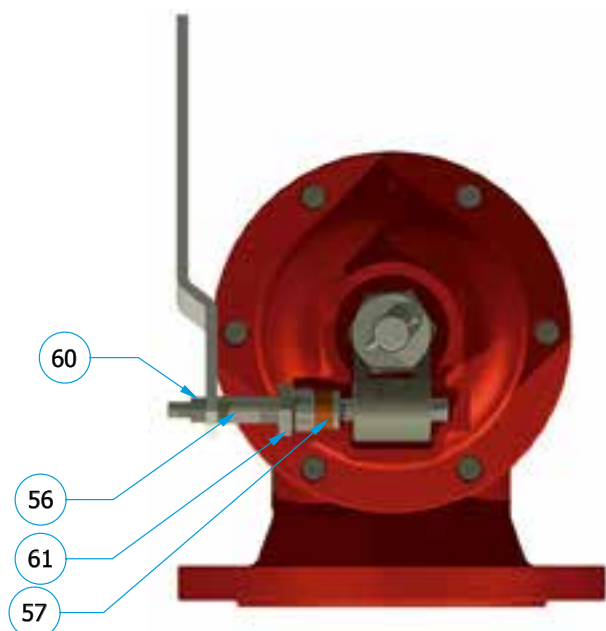
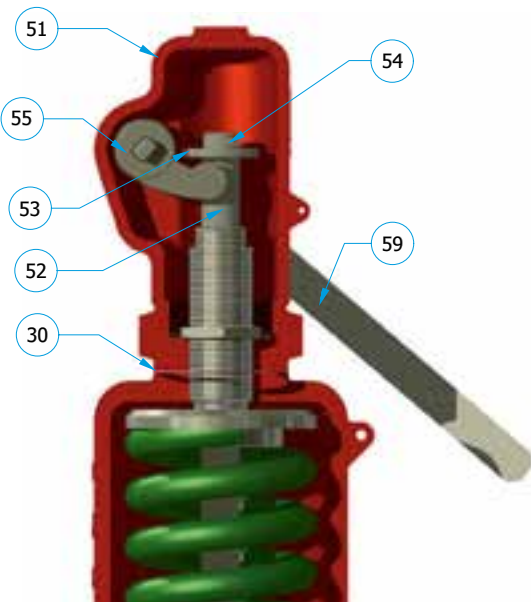

## ■ Bill of materials

CLASS		A	B	E	U
ITEM	DENOMINATION	-29 to 232 °C	233 to 400 °C	-268 to 400 °C	-29 to 343 °C
1	BODY	1.0619	1.0619	1.4408	0.7043
2	BONNET	1.0619	1.0619	1.4408	0.7043
2a	OPEN BONNET	1.0619	1.0619	---	0.7043
3	CAP	1.0619	1.0619	1.4408	0.7043
4	NOZZLE	1.4006 (3)	1.4006 (3)	1.4401	1.4006 (3)
5	DISC	1.4006 (4)	1.4006 (4)	1.4401	1.4006 (4)
6	DISC HOLDER	1.4006 Annealed	1.4006 Annealed	1.4401	1.4006 Annealed
7	ELASTIC RING	1.4401	1.4401	1.4401	1.4401
8	GUIDE	1.4401 (8)	1.4401 (8)	1.4401	1.4401 (8)
9	STEM	1.4021 (5)	1.4021 (5)	1.4401	1.4021 (5)
10	SPRING	50CRV4 C.S.	H21 T.S.	1.4401 (1)	50CRV4 C.S. (9)
11	ADJUSTING SCREW	1.4021 (4)	1.4021 (4)	1.4401 Nitrided	1.4021 (4)
12	ADJUSTING SCREW NUT	1.4401	1.4401	1.4401	1.4401
13	SPHERE	1.4021 (6)	1.4021 (6)	1.4401 (2)	1.4021 (6)
14	FRICTION WASHER	1.4401	1.4300	1.4401	1.4401
15	SPRING BUTTON	C.S. Zincate	C.S. Zincate	1.4401	C.S. Zincate
17	LOCKING RING	1.4401	1.4401	1.4401	1.4401
18	RING	1.4401	1.4401	1.4401	1.4401
23	STUD	1.7225	1.7225	1.4307	1.7225
24	NUT	1.1181	1.1181	1.4307	1.1181
25	PLUG	C.S. Zincate	C.S. Zincate	1.4305	C.S. Zincate
28	PLUG GASKET	Compressed Fibers	Graphite	Compressed Fibers (7)	Compressed Fibers
29	GUIDE GASKET	Compressed Fibers	Graphite	Compressed Fibers (7)	Compressed Fibers
30	CAP GASKET	Compressed Fibers	Graphite	Compressed Fibers (7)	Compressed Fibers
43	PIN	C.S.	C.S.	C.S.	C.S.
51	LEVER CAP	1.0619	1.0619	1.4408	0.7043
52	LEVER STEM	1.4021 (5)	1.4021 (5)	1.4401	1.4021 (5)
53	NUT	C.S. Zincate	C.S. Zincate	1.4401	C.S. Zincate
54	NUT	1.4401	1.4401	1.4401	1.4401
55	CAM	1.4404	1.4404	1.4404	1.4404
56	LEVER SHAFT	1.4021 (3)	1.4021 (3)	1.4401	1.4021 (3)
57	PACKING	BRAID GRAPHITE			
59	LEVER	C.S. Zincate	C.S. Zincate	C.S. Zincate	C.S. Zincate
60	NUT	C.S. - DIN 934	C.S. - DIN 934	1.4301	C.S. - DIN 934
61	PACKING GLAND	C.S. Zincate	C.S. Zincate	1.4401	C.S. Zincate
70	OPEN LEVER CAP	0.6025	0.6025	-	0.7043
71	OPEN CAP LEVER	C.S. Zincate	C.S. Zincate	-	C.S. Zincate
72	OPEN CAP SHAFT	1.4021 (5)	1.4021 (5)	-	1.4021 (5)

(1) Inconel X-750 material for T>300°C  
(2) Nitriding surface treatment  
(3) Quenched and Tempered HB 220 ÷ 280  
(4) Quenched and Tempered HB 350 ÷ 400  
(5) Quenched and Tempered HB 240 ÷ 300

(6) Quenched and Tempered HRC>50  
(7) Graphite material for T>232°C and T<-29°C  
(8) For DN≥50x80: Made of CF8M S.S. casting  
(9) H21 T.S. material for T>232°C





■ **Accessories**

TEST-GAG



PACKED LEVER



PLAIN LEVER



HEATING JACKET





## ■ General Dimensions

Orifice (ø mm)	Rating	Inlet	Outlet	Flow Area (cm <sup>2</sup> )	General Dimensions					Standard	Lever
					A	B	C	E	F	Weight - (Kg)	
18	PN16÷25÷40 x PN16	DN20	DN32	2,54	85	95	294	90	339	7,3	8
0.7043 (D.I.)											
1.0619 (C.S.)											
1.4408 (S.S.)											
23	PN16÷25÷40 x PN16	DN25	DN40	4,15	105	100	344	90	389	10,4	11,1
0.7043 (D.I.)											
1.0619 (C.S.)											
1.4408 (S.S.)											
29	PN16÷25÷40 x PN16	DN32	DN50	6,61	115	110	396	90	446	13,2	14
0.7043 (D.I.)											
1.0619 (C.S.)											
1.4408 (S.S.)											
37	PN16÷25÷40 x PN16	DN40	DN65	10,75	140	115	479	90	529	17,9	18,6
0.7043 (D.I.)											
1.0619 (C.S.)											
1.4408 (S.S.)											
47	PN16÷25÷40 x PN16	DN50	DN80	17,35	150	120	561	100	611	24,8	25,8
0.7043 (D.I.)											
1.0619 (C.S.)											
1.4408 (S.S.)											
60	PN16÷25÷40 x PN16	DN65	DN100	28,27	170	140	682	120	732	40,5	41,7
0.7043 (D.I.)											
1.0619 (C.S.)											
1.4408 (S.S.)											
75	PN16÷25÷40 x PN16	DN80	DN125	44,18	195	160	732	120	792	43,8	45,2
0.7043 (D.I.)											
1.0619 (C.S.)											
1.4408 (S.S.)											
95	PN16÷25÷40 x PN16	DN100	DN150	70,88	220	180	896	150	956	96,7	98,8
0.7043 (D.I.)											
1.0619 (C.S.)											
1.4408 (S.S.)											
106	PN16÷25÷40 x PN16	DN125	DN200	88,25	250	200	996	150	1066	124,5	127,3
0.7043 (D.I.)											
1.0619 (C.S.)											
1.4408 (S.S.)											
125	PN16÷25÷40 x PN16	DN150	DN250	122,72	285	225	1159	150	1229	155,5	159,8
0.7043 (D.I.)											
1.0619 (C.S.)											
1.4408 (S.S.)											

(D.I.) Ductile Iron  
(C.S.) Carbon Steel  
(S.S.) Stainless Steel

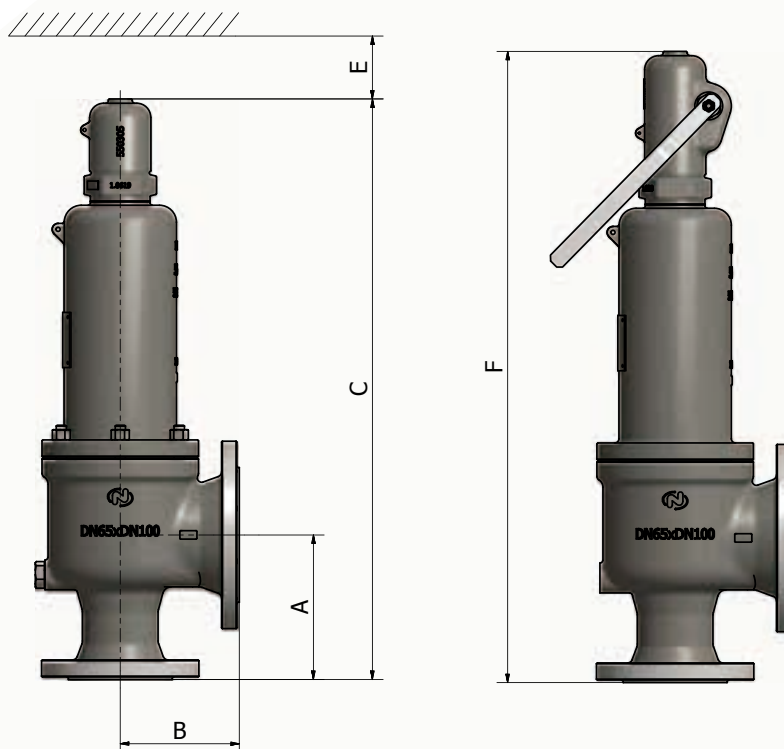

■ **Safety valve main components**

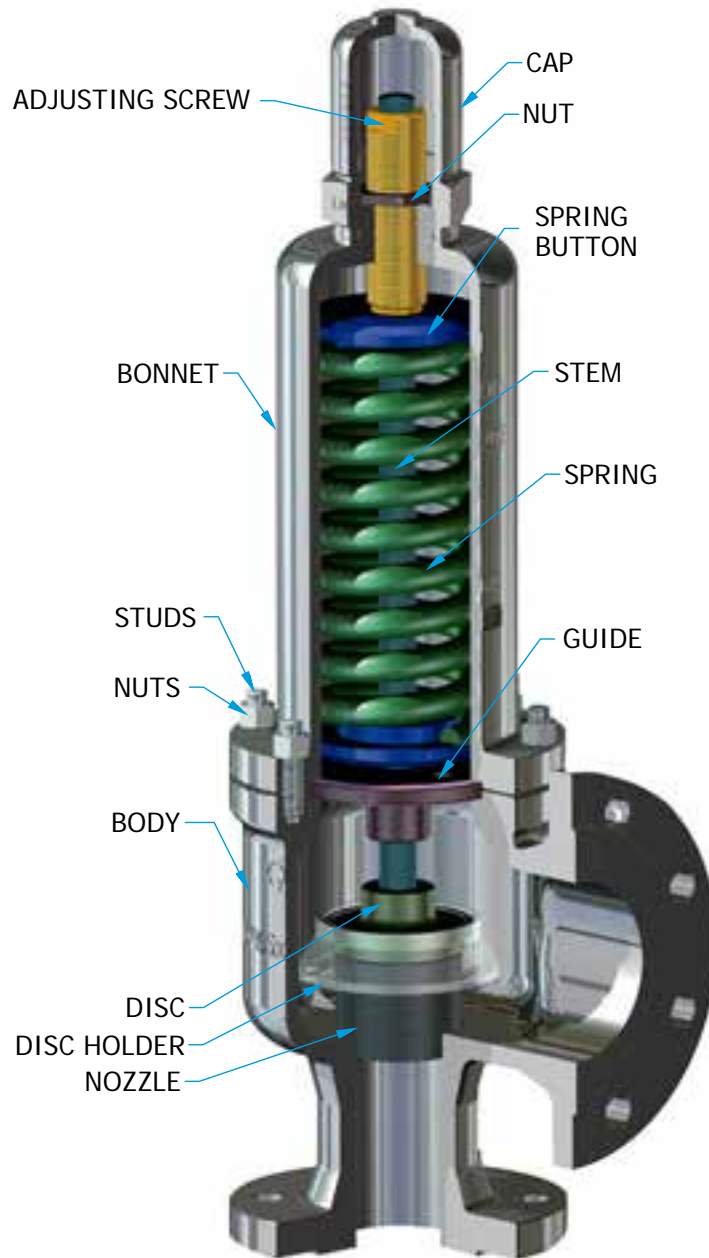

■ **Technical Information / Operating technical characteristics table**

SAFETY VALVE MODEL 5500				
SERVICE			GAS	LIQUID
DISCHARGE COEFFICIENT (at 10% of overpressure)	(1) (2)	Kd	0,90	0,70
BLOWDOWN		MAX. MIN.	-10% (4) -5%	-20% (5) -10%
SUPERIMPOSED BACK PRESSURE	(3)	MAX.	10%	
BUILT-UP BACKPRESSURE	(3)	MAX.	15%	
SET PRESSURE TOLERANCE	(6)	±	3%	
MINIMUM SET PRESSURE	ASME VIII Div.1 (bar) EN ISO 4126-1 (bar)		1 0,5	

(1) or 0,1 bar, whichever is greater  
 (2) Coefficient certificated at the Laboratorio Politecnico di Milano  
 (3) Maximum allowable backpressure without overpressure exceeds 10%  
 (4) or 0,2 bar, whichever is greater  
 (5) or 0,6 bar, whichever is greater  
 (6) or ± 0,15 bar, whichever is greater

## ■ Technical information

### Gases discharge flow / Capacity chart - Air

$$A = \frac{W}{387,2 \cdot C \cdot P \cdot K \cdot K_1 \cdot K_2} \cdot \sqrt{\frac{Z \cdot T}{M}}$$

Values used in formulas											
Flow		Nm <sup>3</sup> /h		Temperature 15° C							
Overpressure		10% (*)		Atmospheric Barckpressure							
Orificies Area cm <sup>2</sup>	Kg/cm <sup>2</sup>	Ø18	Ø23	Ø29	Ø37	Ø47	Ø60	Ø75	Ø95	Ø106	Ø125
		2,54	4,15	6,61	10,75	17,34	28,27	44,17	70,88	88,25	122,72
0,5	233	381	607	987	1591	2595	4054	6505	8099	11263	
1	300	491	781	1271	2049	3341	5221	8378	10431	14505	
1,5	367	600	956	1555	2507	4088	6387	10250	12762	17746	
2	434	710	1130	1838	2966	4835	7554	12122	15093	20988	
2,5	508	829	1321	2149	3466	5650	8828	14167	17638	24528	
3	581	950	1513	2461	3970	6472	10111	16226	20202	28093	
3,5	655	1071	1705	2773	4473	7293	11395	18285	22767	31659	
4	729	1191	1897	3086	4977	8114	12678	20345	25331	35225	
4,5	803	1312	2089	3398	5481	8936	13962	22404	27895	38790	
5	877	1432	2281	3710	5985	9757	15245	24464	30459	42356	
6	1024	1674	2666	4335	6992	11400	17812	28583	35587	49488	
7	1172	1915	3050	4960	8000	13043	20379	32702	40716	56619	
8	1319	2156	3434	5584	9008	14686	22945	36821	45844	63750	
9	1467	2397	3818	6209	10015	16328	25512	40940	50972	70882	
10	1615	2638	4202	6834	11023	17971	28079	45059	56101	78013	
11	1762	2879	4586	7458	12031	19614	30646	49177	61229	85145	
12	1910	3120	4970	8083	13038	21257	33212	53296	66357	92276	
13	2057	3362	5354	8708	14046	22900	35779	57415	71486	99408	
14	2205	3603	5738	9333	15054	24543	38346	61534	76614	106539	
15	2353	3844	6123	9957	16061	26185	40913	65653	81742	113670	
16	2500	4085	6507	10582	17069	27828	43480	69772	86871	120802	
17	2648	4326	6891	11207	18077	29471	46046	73891	91999	127933	
18	2796	4567	7275	11831	19084	31114	48613	78010	97127	135065	
19	2943	4809	7659	12456	20092	32757	51180	82129	102256	142196	
20	3091	5050	8043	13081	21100	34399	53747	86248	107384	149328	
25	3829	6256	9964	16204	26138	42613	66581	106843	133026	184985	
30	4567	7461	11884	19328	31176	50827	79415	127437	158667	220642	
35	5305	8667	13805	22451	36214	59042	92248	148032	184309	256299	
40	6043	9873	15725	25575	41253	67256	105082	168627	209951	291956	
45	6781	11079	17646	28698	46291	75470	117916	189221	235592	327613	
50	7519	12285	19567	31822	51329	83684	130750	209816	261234	363270	

(\*) Minimum overpressure 0,2 barg  
 Different temperature to 15° C, multiply by K<sub>t</sub>  
 k values different to k=1,41, multiply by K<sub>c</sub>  
 For other fluids or working conditions use the formulas.



## ■ Technical information

### Steam discharge flow / Capacity chart - steam

$$A = \frac{W}{112,7 \cdot C \cdot K \cdot K_1 \cdot K_2} \cdot \sqrt{\frac{V_1}{P}}$$

Values used in formulas										
Flow	Kg/h									
Overpressure	10% (*)									
Orifices Area cm <sup>2</sup>	Ø18	Ø23	Ø29	Ø37	Ø47	Ø60	Ø75	Ø95	Ø106	Ø125
Kg/cm <sup>2</sup>	2,54	4,15	6,61	10,75	17,34	28,27	44,17	70,88	88,25	122,72
0,5	202	330	526	855	1379	2248	3512	5635	7016	9757
1	259	422	673	1094	1765	2878	4497	7216	8984	12494
1,5	314	513	817	1329	2144	3495	5460	8762	10910	15171
2	370	604	962	1565	2524	4116	6430	10319	12848	17866
2,5	433	708	1128	1834	2958	4823	7535	12092	15056	20936
3	486	794	1265	2057	3319	5410	8454	13565	16890	23487
3,5	549	898	1430	2326	3751	6116	9556	15334	19092	26549
4	618	1010	1608	2616	4219	6879	10747	17246	21473	29860
4,5	676	1104	1758	2860	4613	7521	11751	18857	23478	32648
5	733	1198	1908	3104	5006	8162	12753	20464	25479	35431
6	846	1382	2202	3581	5776	9416	14712	23609	29395	40876
7	960	1569	2499	4064	6556	10688	16700	26798	33365	46397
8	1074	1755	2796	4547	7335	11958	18684	29983	37330	51911
9	1188	1941	3092	5028	8111	13223	20661	33154	41279	57403
10	1329	2171	3458	5624	9072	14790	23109	37083	46170	64204
11	1439	2351	3745	6090	9823	16015	25022	40153	49993	69520
12	1552	2536	4040	6570	10597	17277	26994	43318	53934	75000
13	1665	2721	4334	7048	11369	18535	28960	46472	57860	80460
14	1779	2906	4629	7529	12144	19799	30935	49641	61806	85947
15	1893	3092	4925	8010	12920	21064	32912	52814	65756	91440
16	2006	3278	5220	8490	13695	22327	34884	55979	69697	96920
17	2119	3462	5514	8968	14465	23583	36846	59128	73618	102372
18	2287	3736	5951	9679	15612	25453	39768	63817	79456	110491
19	2401	3922	6248	10161	16389	26720	41748	66994	83411	115991
20	2515	4108	6544	10642	17167	27987	43728	70171	87367	121493
25	3077	5028	8008	13023	21007	34248	53511	85869	106912	148672
30	3650	5963	9498	15447	24916	40621	63467	101846	126805	176335
35	4214	6886	10968	17837	28771	46906	73288	117606	146427	203621
40	4851	7926	12625	20532	33119	53995	84364	135380	168557	234394

(\*) Minimum overpressure 0,2 barg  
Saturated steam values  
For superheated steam, multiply by k<sub>s</sub>  
For other fluids or working conditions use the formulas.

## ■ Technical information

### Liquids discharge flow / Capacity chart - liquids

$$A = \frac{W}{5042 \cdot K \cdot K_3 \cdot K_v \cdot \sqrt{(P - P_b)} \cdot E}$$

Values used in formulas										
Flow		m <sup>3</sup> /h								
Overpressure		10% (*)								
Orificies Area cm <sup>2</sup>	Ø18	Ø23	Ø29	Ø37	Ø47	Ø60	Ø75	Ø95	Ø106	Ø125
Kg/cm <sup>2</sup>	2,54	4,15	6,61	10,75	17,34	28,27	44,17	70,88	88,25	122,72
1	8,43	13,78	21,94	35,68	57,56	93,84	146,62	235,28	292,94	407,36
2	11,41	18,64	29,69	48,28	77,88	126,97	198,38	318,33	396,35	551,16
3	13,96	22,81	36,33	59,08	95,29	155,36	242,74	389,52	484,98	674,41
4	16,12	26,33	41,95	68,22	110,03	179,39	280,29	449,78	560,01	778,75
5	18,02	29,44	46,90	76,27	123,02	200,57	313,37	502,87	626,11	870,66
6	19,74	32,25	51,37	83,55	134,76	219,71	343,28	550,87	685,87	953,77
7	21,32	34,84	55,49	90,24	145,56	237,32	370,79	595,01	740,82	1030,18
8	22,79	37,24	59,32	96,47	155,61	253,70	396,39	636,09	791,97	1101,31
9	24,18	39,50	62,92	102,32	165,05	269,09	420,44	674,68	840,01	1168,12
10	25,48	41,64	66,32	107,86	173,98	283,65	443,18	711,17	885,45	1231,31
11	26,73	43,67	69,56	113,12	182,47	297,49	464,81	745,88	928,67	1291,40
12	27,92	45,61	72,65	118,15	190,59	310,72	485,48	779,05	969,96	1348,83
13	29,06	47,48	75,62	122,98	198,37	323,41	505,30	810,86	1009,57	1403,90
14	30,15	49,27	78,47	127,62	205,86	335,61	524,37	841,47	1047,68	1456,90
15	31,21	51,00	81,23	132,10	213,08	347,39	542,78	871,00	1084,45	1508,03
16	32,24	52,67	83,89	136,43	220,07	358,79	560,58	899,57	1120,02	1557,49
17	33,23	54,29	86,47	140,63	226,84	369,83	577,83	927,25	1154,49	1605,43
18	34,19	55,86	88,98	144,71	233,42	380,55	594,59	954,14	1187,96	1651,97
19	35,13	57,40	91,42	148,67	239,81	390,98	610,88	980,28	1220,51	1697,24
20	36,04	58,89	93,79	152,54	246,04	401,14	626,75	1005,75	1252,22	1741,33
21	36,93	60,34	96,11	156,30	252,12	411,04	642,23	1030,58	1283,14	1784,33
22	37,80	61,76	98,37	159,98	258,05	420,71	657,34	1054,84	1313,34	1826,32
23	38,65	63,15	100,58	163,58	263,85	430,17	672,11	1078,54	1342,85	1867,37
24	39,48	64,51	102,74	167,10	269,53	439,42	686,57	1101,74	1371,74	1907,53
25	40,30	65,84	104,86	170,54	275,09	448,48	700,73	1124,46	1400,02	1946,86
26	41,09	67,14	106,94	173,92	280,53	457,36	714,60	1146,73	1427,75	1985,42
27	41,88	68,42	108,98	177,23	285,88	466,08	728,22	1168,57	1454,95	2023,24
28	42,64	69,68	110,98	180,48	291,12	474,63	741,58	1190,02	1481,65	2060,37
29	43,40	70,91	112,94	183,68	296,28	483,03	754,70	1211,08	1507,87	2096,84
30	44,14	72,12	114,87	186,82	301,34	491,29	767,61	1231,78	1533,65	2132,68
31	44,87	73,31	116,77	189,91	306,32	499,41	780,29	1252,15	1559,00	2167,94
32	45,59	74,49	118,64	192,95	311,23	507,40	792,78	1272,18	1583,95	2202,63
33	46,30	75,64	120,48	195,94	316,05	515,27	805,07	1291,91	1608,50	2236,78
34	46,99	76,78	122,29	198,88	320,80	523,02	817,18	1311,33	1632,69	2270,41
35	47,68	77,90	124,08	201,79	325,49	530,65	829,11	1330,48	1656,53	2303,56
36	48,35	79,00	125,84	204,65	330,10	538,18	840,87	1349,35	1680,03	2336,24
37	49,02	80,09	127,57	207,47	334,66	545,60	852,47	1367,97	1703,20	2368,46
38	49,68	81,17	129,28	210,26	339,15	552,93	863,91	1386,33	1726,06	2400,26
39	50,33	82,23	130,97	213,01	343,58	560,16	875,21	1404,45	1748,63	2431,63
40	50,97	83,28	132,64	215,72	347,96	567,29	886,36	1422,34	1770,90	2462,61

(\*) Minimum overpressure 0,2 barg  
The results shown correspond to calculations for water at 20°C  
For different relative densities of water to 1, multiply by Kg  
For other fluids or working conditions use formulas.



## ■ Definitions (EN ISO 4126-1)

**Blowdown:** The difference between the set and re-seating pressures, normally stated as a percentage on the set pressure of a safety valve except for pressures of less than 3 bar when it is expressed to operate.

**Built-up back pressure:** The pressure existing at the outlet of the safety valve caused by flow through the valve and the discharge system

**Coefficient of discharge:** The value of actual flowing capacity (from tests).

**Cold differential test pressure:** The inlet static pressure at which a safety valve is set to initiate to open on the test bench. This test pressure includes corrections for service conditions, as back pressure and/or temperature.

**Flow area:** The minimum cross-sectional flow area (but not the curtain area) between inlet and nozzle which is used to calculate the theoretical flow to discharge.

**Flow diameter:** The diameter corresponding to the flow area.

**Lift:** The actual travel of the valve disc starting from the closed position.

**Maximum allowable pressure:** The maximum pressure for which the equipment is designed as specified by the manufacturer.

**Overpressure:** A pressure increase over the set pressure, at which the safety valve achieves the lift specified by the manufacturer, usually expressed as a percentage of the set pressure.

**Pressure:** The pressure unit used in this standard is the bar (1 bar =  $10^5$  Pa). It is quoted as gauge (relative to atmospheric pressure) or absolute as appropriate.

**Relieving pressure:** The pressure used for the sizing of the safety valve which is greater than or equal to the set pressure plus the overpressure.

**Re-seating pressure:** The value of the inlet static pressure at which the disc re-establishes contact with the seat or at which the lift becomes zero.

**Safety valve:** Valve which automatically, without the assistance of any energy other than that of the fluid concerned, discharges a quantity of the fluid so as to prevent a predetermined safe pressure being exceeded and which is designed to re-close and prevent further flow or fluid after nominal pressure conditions of service have been restored.

**Set pressure:** The predetermined pressure at which a safety valve under operating conditions initiates to open.

**Superimposed back pressure:** The pressure existing at the outlet of the safety valve at the time when the device is required to operate.

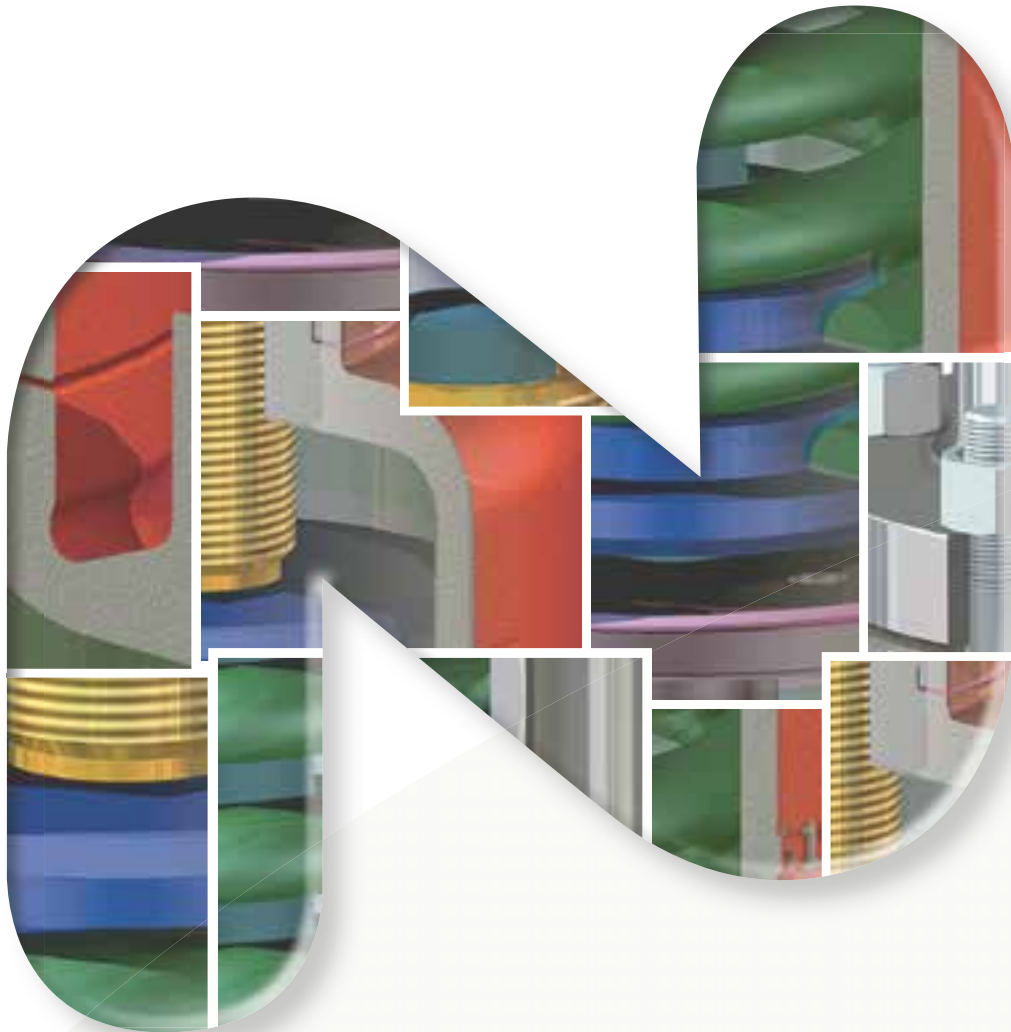

# VALVE 5500

Safety valve specially designed to work  
with gases, vapor or liquids for  
industrial applications.





C/ Chopín, 2 - 4 - Pol. Ind Can Jardí  
08191 Rubí (Barcelona) Spain  
Tel.: +34 936 995 200  
Fax: +34 936 974 556  
[safety@valvulasnacional.com](mailto:safety@valvulasnacional.com)  
[www.valvulasnacional.com](http://www.valvulasnacional.com)

Member of Pecos group

