

**6400**





## ■ The Company

### Production, R+D+i, evolution.



VALVULAS NACIONAL, S.A. was established in Spain in 1976. The main target was to assist the petrochemical and chemical industries emerging in Spain at that time. Right from the start VALVULAS NACIONAL, S.A., has been designing and producing safety valves according to most recognized international standards and norms: API, ASME, ASTM and the European directives 97/23 & 94/9 CE. Our production process is accredited by an ISO 9001-2008 certification.

Our know how and capacity to adapt to the constantly changing demands of the market, made possible the introduction of new products designed for new applications in the market, like THERMOSOLAR PLANTS, where VALVULAS NACIONAL has supplied safety valves to more than 16 complete plants all over the world, while at the same time continuously supplying to all the main players in the Spanish petrochemical, chemical and refining industries.

### Production capacity.



VALVULAS NACIONAL, S.A. valves' have their discharge coefficients approved in laboratory tests, in order to guarantee and assure the correct values are being used for every sizing process.

In our Technical sales department we work with a modern software which allows us to verify all the possibilities, and to assure strict fulfillment of all international standards.

VALVULAS NACIONAL, S.A. has established representation agreements with the most important O.E.M. companies in the safety sector of the industry, consolidating us as one of the main companies by product range; design and consulting in new plants or in new process.

Our continuous growth, shows a clear trend, which confirms the integration of our workers to provide first class service to our customers and partners.

### Factory & location.



Our facilities are Rubí (Barcelona - Spain), with more than 1.200 m<sup>2</sup> are fully prepared for our production activities: machining with modern CNC, assembling and testing. We also have long term agreements with approved workshops, which provides us with flexibility and fast feedback to customers demands, with full quality guarantee which has always been our main target.

### Strategic alliances.

Nowadays VALVULAS NACIONAL, S.A. starts an internationalization process, establishing representation agreements in different countries and continents all over the world, with specialized companies that will provide added value in our service towards the end user.

VALVULAS NACIONAL providing safety since 1976 !

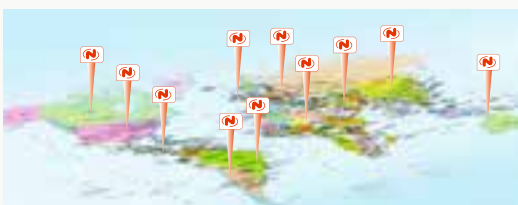

■ **Index**

• GENERAL FEATURES	<b>4</b>
NAMEPLATE	<b>5</b>
• OPERATION	<b>5</b>
CONSTANT BACK PRESSURE OPERATION	<b>6</b>
VARIABLE BACK PRESSURE OPERATION	<b>6</b>
• CODIFICATION SYSTEM	<b>7</b>
• PART LIST	<b>8</b>
• BILL OF MATERIALS	<b>9</b>
• ACCESSORIES	<b>10</b>
• GENERAL DIMENSIONS	<b>11</b>
• TECHNICAL INFORMATION	<b>12</b>
OPERATING CHARACTERISTICS TABLE	<b>12</b>
CALCULATION FORMULAS FOR ORIFICE AREA	<b>13</b>
CONSTANTS	<b>14</b>
VALUES OF K AND C	<b>15</b>
CORRECTION COEFFICIENTS CHARTS	<b>16</b>
GASES DISCHARGE FLOW	<b>17</b>
STEAM DISCHARGE FLOW	<b>18</b>
LIQUIDS DISCHARGE FLOW	<b>19</b>
CORRECTION FACTORS	<b>20</b>
API SELECTION CHART	<b>21</b>
REACTION FORCES DURING DISCHARGE	<b>28</b>
NOISE DISCHARGE CALCULATION	<b>29</b>
• DEFINITIONS (ASME PTC-25)	<b>30</b>

## ■ General features

Model 6400, is an angular type safety valve at 90° between the inlet and the outlet connections, with flanged connections, full nozzle, direct action and spring loaded. Subdivided into three types: Conventional, Balanced (with bellows) and Balanced-Piston. All three are designed with specific trims to work with gases and vapours or liquids.

### DESIGN

- Valve body is angular type at 90° between inlet and outlet flanges. Its large internal capacity and smooth section changes help reducing turbulences. Therefore, fluid evacuation on discharge is improved.
- Full nozzle type, guided and screwed to body, enabling perfect alignment and easy disassembling.
- Disc is separate from disc-holder, for that reason its repair or change is improved and a better selection of materials can be performed.
- Stem-push rod design in two parts, enables push rod material to be hardened to withstand high charges, facilitating displacement, avoiding seizure with guide.
- Guide has a large push rod guide area to prevent premature damage, ensuring perfect alignment with all internals.
- Bellows are performed so its average area is equal to orifice area thus achieving perfect valve balance and consequently perfect operation before variable back pressures. Its meticulous design enables maximum pressures and temperatures to be supported achieving a high degree of elasticity.
- Springs are designed with an experimented highly reliable calculation software and manufactured with the ideal material qualities for the process conditions, ensuring elasticity and accurate repetition of valve opening.
- For design of the different valve types has taken into account standardisation, enabling a conventional type valve to be converted into balanced with minimum parts change.

### CODES AND STANDARDS

Valves have been designed and manufactured in compliance with the following directives, codes and standards:

European Directive:	97/23/CE (PED)
European Directive:	94/9/CE (ATEX)
Design:	EN ISO-4126-1 & ASME VIII DIV-1
Certifications:	PED MODUL B+D / ASME "UV" & "NB"
Pressure and Temperature Limits:	API-526 & ASME 16.34
Tests:	API-527 & ASME 16.34
Quality system:	EN ISO-9001:2008
Materials:	ASTM/ASME & EN

### SIZES AND RATINGS

Standard sizes and ratings:

ANSI:	
Sizes:	1"x2" up to 12"x16"
Rating:	150# up to 2500#
EN/ISO:	
Sizes:	DN-25xDN-50 up to DN-300xDN-400
Rating:	PN-10 up to PN-420

- This catalogue reflects standard valves. Upon request, our technical department can design special applications.
- The safety valve is an automatic direct action accessory whose function is to relief excessive overpressures in the recipients and installations that protects. Its main characteristics, allowing is its sudden fluid discharge with complete and fast opening (pop).
- Automatic valve opening is produced because of the additional push provided by the overpressure of the fluid itself helping to overcome spring resistance. Once the installation has recovered its normal service condition, the valve closes again.
- Safety valve behaviour is totally different according to whether the fluid it works with on the installation is in gas or liquid phases. To achieve good valve functioning and correct dimensioning, this model was designed with internals for working with gas (Type-64G □) or liquid (Type 64L □).

## NAMEPLATE EN ISO 4126-1/ASME VIII Div.1



### ■ OPERATION

The safety valve which protects a pressurized recipient or installation, remains closed until the force exerted by the pressure of fluid  $P_1$ , against the disc, is equal to the force of spring  $F_r$ . (Fig.1). From this point of equilibrium, the disc holder comes away the nozzle, releasing a small amount of fluid, (valve set pressure) which is deposited in the ring chamber (C) formed between the disc holder and adjusting ring (Fig. 2). Chamber pressurization (C) creates an additional force contributing to total instantaneous valve opening (Fig.3). Maximum valve elevation must be achieved without the installation exceeding 10% of overpressure, regardless of whether fluid is in gas or liquid phase.

Once cause creating the overpressure has disappeared, pressure will reduce in the installation to a certain value belows the set pressure, leaving the valve totally closed. The difference between set pressure and re-seating pressure (blowdown), may be between 7% and 15% depending on whether valve works with gas or liquid.

Overpressure and blowdown values may be corrected positioning the adjusting ring more or less distant from the internal disc holder surface.

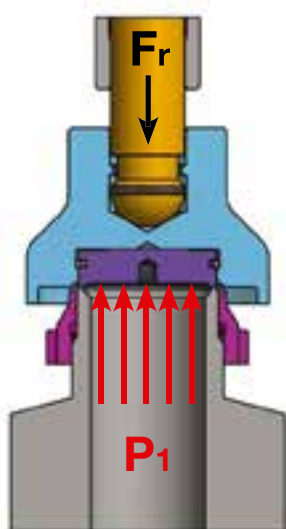

Fig.1

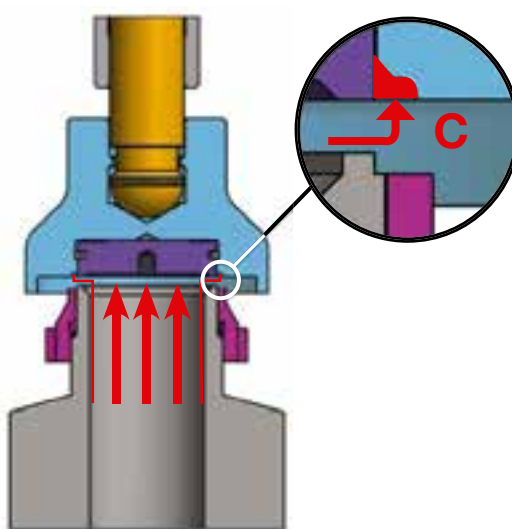

Fig.2

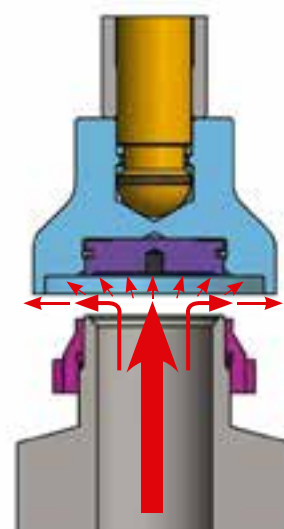

Fig.3

### OPERATION AT **CONSTANT BACK PRESSURE**

When a conventional safety valve (without bellows) Type 64 □ C, is installed in a location where fluid discharge is performed on a pressurized collector, with constant pressure ( $P_2$ ), one must take into account this back pressure value. This back pressure influences on the upper and lower disc holder surface, remaining balanced except for the bottom area occupied by the inlet orifice valve ( $S_a$ ) where back pressure does not act. This decompensation results in an additional force added to the spring effort. Therefore, at the time of adjusting valve pressure on the test bench, one must subtract from set pressure ( $P_1$ ), the constant back pressure ( $P_2$ ). If the valve is balanced (with bellows) Type 64 □ F, correction is not necessary as detailed below.

### OPERATION AT **VARIABLE BACK PRESSURE**

If conventional valve Type 64 □ discharges fluid into a collector where back pressure is variable, then the set pressure is affected by the same variation. If this variation is inadmissible (10% greater than set pressure), a balanced valve (with bellows) Type 64 □ F must be installed.

Bellows function is to eliminate effects caused by back pressure.

As bellows mean diameter area ( $S_f$ ), equals the valve inlet orifice area ( $S_a$ ), it isolates the disc holder upper surface from back pressure action, setting it to atmospheric pressure through the vent hole in valve bonnet. As decompensation of areas produced in conventional valves is eliminated, additional efforts on the spring are eliminated. Therefore, when the valve set pressure is adjusted on the test bench, no back pressure correction at all is required.

### **BACK PRESSURE EFFECT**

When valve initiates opening under back pressure influence due to built-up back pressure or superimposed back pressure, two conditions occur preventing the valve from achieving total elevation without exceeding 10% overpressure: The force on the upper disc holder surface, and pressure reduction on the lower disc holder surface due to disturbances generated on discharging fluid.

Back pressure data indicated on the operation technical characteristics table, are experimental back pressures performed in laboratory on different valve types, and at no time exceeding the maximum overpressure of 10%.

**CONVENTIONAL VALVE**

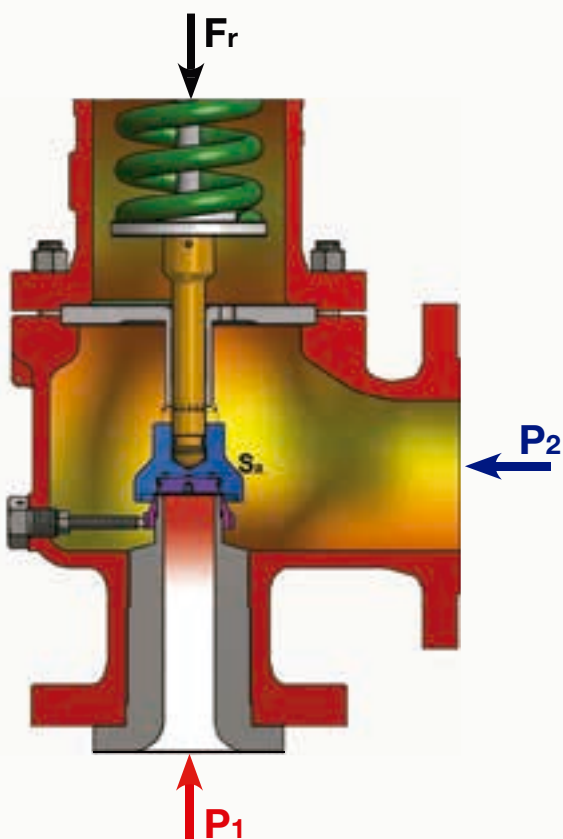

**BELLOWS VALVE**

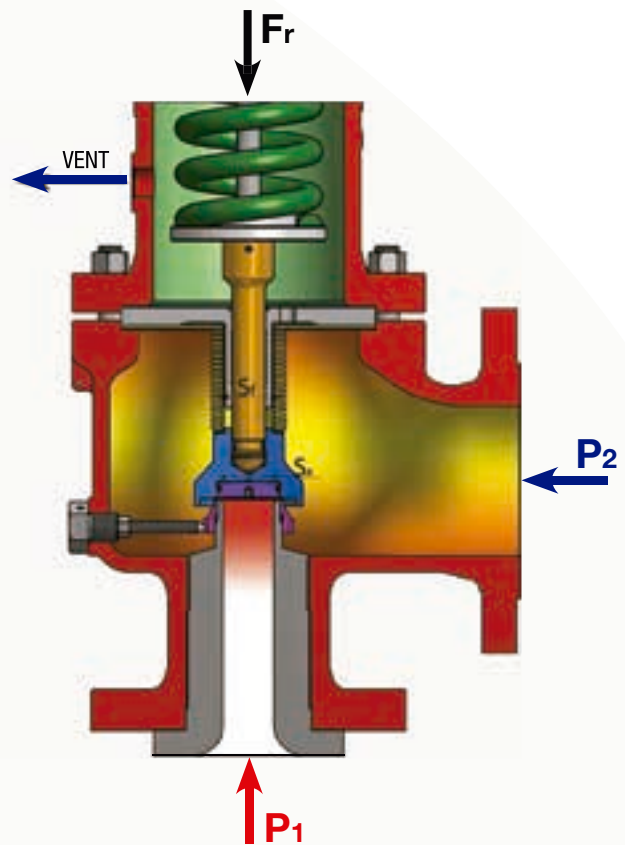



## ■ Codification system

<b>64</b>	<b>G</b>	<b>C</b>	<b>2</b>	<b>J</b>	<b>3</b>	<b>2</b>	<b>1</b>	<b>A</b>	<b>2</b>	<b>X0</b>
1 <sup>st</sup>	2 <sup>nd</sup>	3 <sup>rd</sup>	4 <sup>th</sup>	5 <sup>th</sup>	6 <sup>th</sup>	7 <sup>th</sup>	8 <sup>th</sup>	9 <sup>th</sup>	10 <sup>th</sup>	11 <sup>th</sup>

**1<sup>st</sup> DIGIT:** Valve model

**2<sup>nd</sup> DIGIT:** Work fluid state  
G: Gas and Vapour  
L: Liquid

**3<sup>rd</sup> DIGIT:** Valve type  
C: Conventional  
F: Bellows  
P: Bellows-Piston

**4<sup>th</sup> DIGIT:** Inlet nominal size

**5<sup>th</sup> DIGIT:** Orifice size

**6<sup>th</sup> DIGIT:** Outlet nominal size

**7<sup>th</sup> DIGIT:** Inlet rating  
1: ASME 150  
2: ASME 300  
3: ASME 600  
4: ASME 900  
5: ASME 1500  
6: ASME 2500  
A: PN-10  
B: PN-16  
C: PN-25  
D: PN-40  
E: PN-63  
F: PN-100  
G: PN-160  
H: PN-250

**8<sup>th</sup> DIGIT:** Outlet rating  
(Same 7<sup>th</sup> Digit)

**9<sup>th</sup> DIGIT:** Standard quality materials

**10<sup>th</sup> DIGIT:** Material Subclass (Nozzle and Disc) - (see bill of materials)

**11<sup>th</sup> DIGIT:** Standards accesories

<b>X0</b>	Packed Lever
<b>X1</b>	Test Gag
<b>X2</b>	Packed lever + Test Gag
<b>X3</b>	Open Bonnet
<b>X4</b>	Open Bonnet + Test Gag
<b>X5</b>	Open Bonnet + Test Gag + Packed Lever
<b>Y4</b>	Plain Lever
<b>Y5</b>	Plain Lever + Test Gag
<b>Z2</b>	O Ring
<b>Z4</b>	Inconel X-750 Spring
<b>W1</b>	Open bonnet + Packed lever
<b>W4</b>	Nozzle with "Stellite"
<b>W5</b>	Disc with "Stellite"
<b>V0</b>	Magnetic sensor

■ **Part list**

**CONVENTIONALL VALVE**

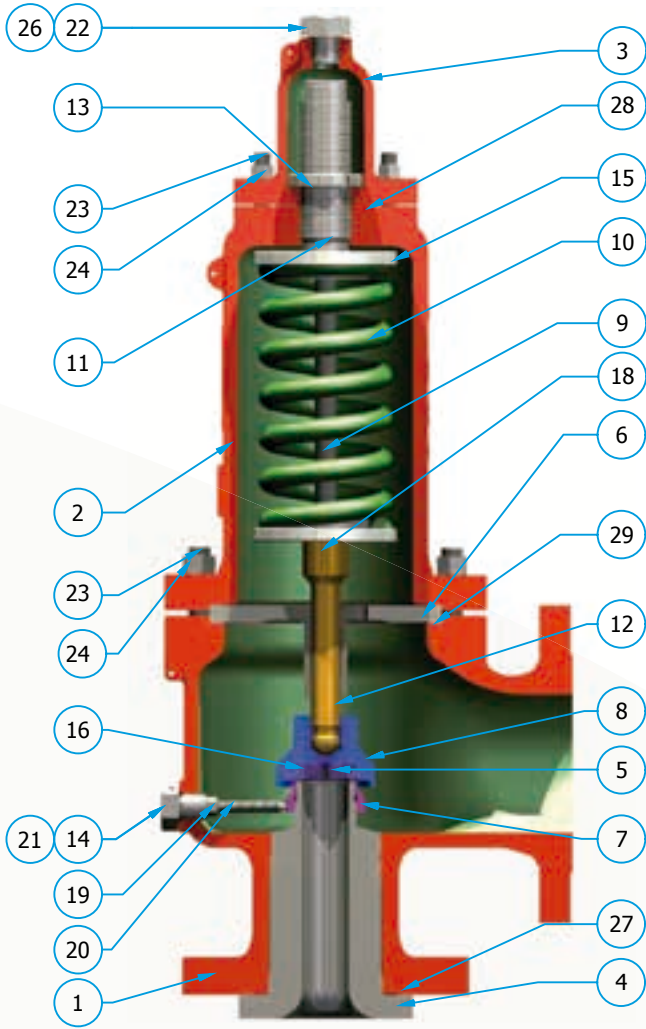

**BELLOWS VALVE**

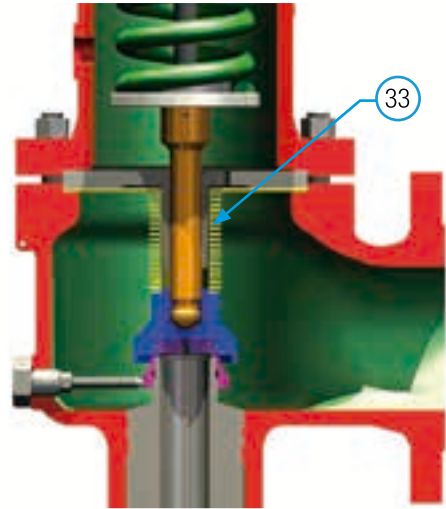

**BELLOWS-PISTON VALVE**

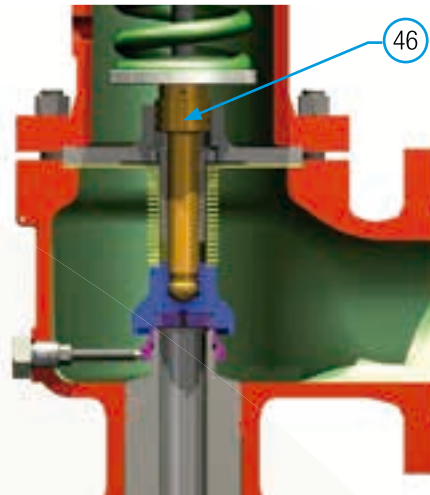

**LEVER OPTION**

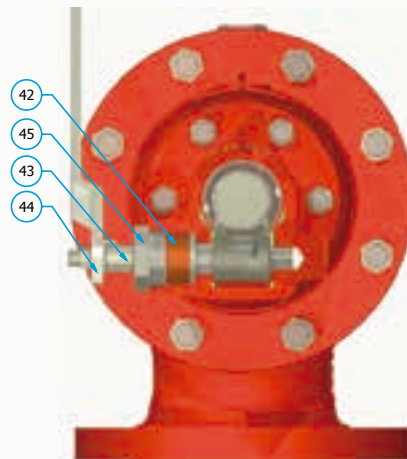
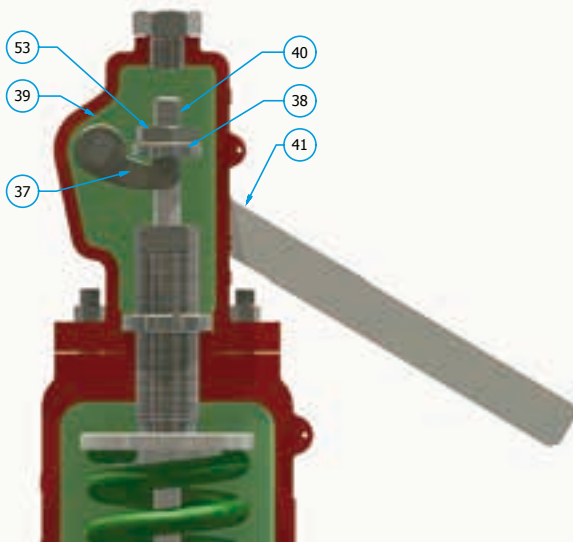





## Bill of materials

CLASS		A	B	C	D	E	N1 (Duplex)	O (Super Duplex)	NACE - A
ITEM	DENOMINATION	-29 to 232 °C	233 to 425 °C	426 to 538 °C	-45 to 232 °C	-268 to 538 °C	-29 to 260°C	-29 to 316°C	-29 to 425 °C
1	BODY	SA 216 WCB	SA 216 WCB	SA 217 WC6	SA 352 LCB	SA 351 CF8M	SA 995 CD4MCuN	SA 995 CD3MWCuN	SA 216 WCB
2	BONNET	SA 216 WCB	SA 216 WCB	SA 217 WC6	SA 352 LCB	SA 351 CF8M	SA 995 CD4MCuN	SA 995 CD3MWCuN	SA 216 WCB
2a	OPEN BONNET	SA 216 WCB	SA 216 WCB	SA 216 WCB	----	----	----	----	SA 216 WCB
3	CAP	SA 216 WCB (1)	SA 216 WCB (1)	SA 216 WCB (1)	SA 216 WCB (1)	SA 351 CF8M (1)	SA 351 CF8M (1)	SA 351 CF8M (1)	SA 216 WCB (1)
4	NOZZLE	SEE SUBCLASS							
5	DISC								
6	GUIDE	A 351 CF8M (2)	A 351 CF8M (2)	A 351 CF8M (2)	A 351 CF8M (2)	A 351 CF8M (2)	A 351 CF8M (2)	A 479 S32760 (17)	A 351 CF8M (2)
7	ADJUSTING RING	A 351 CF8M (3)	A 351 CF8M (3)	A 351 CF8M (3)	A 351 CF8M (3)	A 351 CF8M (3)	A 351 CF8M (3)	A 479 S32760 (17)	A 351 CF8M (3)
8	DISC HOLDER	A 479 431 (4) (6)	A 479 431 (4) (6)	A 479 431 (4) (6)	A 351 CF8M (2)	A 351 CF8M (2)	A 351 CF8M (2)	A 479 S32760 (17)	A 351 CF8M (2)
9	STEM	A 479 431 (5)	A 479 431 (5)	A 479 431 (5)	A 479 316	A 479 316	A 479 316	A 479 316	A 479 316
10	SPRING	50CRV4 C.S.	H21 T.S. (15)	H21 T.S. (15)	A 313 316	A 313 316 (11)	A 313 316 (11)	A 313 316 (11)	INCONEL X-750
11	ADJUSTING SCREW	A 479 431 (6)	A 479 431 (6)	A 479 431 (6)	A564 630	A564 630	A564 630	A564 630	A564 630
12	PUSH ROD	A 479 431 (6)	A 479 431 (6)	A 479 431 (6)	A 564 630 (10)	A 564 630 (10)	A 564 630 (10)	A 564 630 (10)	A 564 630 (10)
13	NUT	C.S. (7)	C.S. (7)	C.S. (7)	A 479 316	A 479 316	A 479 316	A 479 316	C.S. (7)
14	LOCK SCREW	C.S. (7)	C.S. (7)	C.S. (7)	S.S.	S.S.	S.S.	A 479 S32760 (17)	C.S. (7)
15	SPRING BUTTON	C.S. (7)	C.S. (7)	C.S. (7)	A 479 316	A 479 316	A 479 316	A 479 316	C.S. (7)
16	ELASTIC RING	316 S.S.	316 S.S.	316 S.S.	316 S.S.	316 S.S.	316 S.S.	316 S.S.	316 S.S.
17	PLUG	C.S. (7)	C.S. (7)	C.S. (7)	S.S.	S.S.	S.S.	A 479 S32760 (17)	C.S. (7)
18	ELASTIC PIN	302 S.S.	302 S.S.	302 S.S.	302 S.S.	302 S.S.	302 S.S.	302 S.S.	302 S.S.
19	NUT	316 S.S.	316 S.S.	316 S.S.	316 S.S.	316 S.S.	316 S.S.	A 479 S32760 (17)	316 S.S.
20	LOCK STUD	316 S.S.	316 S.S.	316 S.S.	316 S.S.	316 S.S.	316 S.S.	316 S.S.	316 S.S.
21	GASKET	Compressed Fibers	Graphite+316 S.S. (9)			Compressed Fibers (12)			
22	PLUG	C.S. (7)	C.S. (7)	C.S. (7)	S.S.	S.S.	S.S.	S.S.	C.S. (7)
23	STUDS	SA 193 B7 (7)	SA 193 B7 (7)	SA 193 B16 (7)(17)	SA 193 B8 (7)	SA 193 B8 (7)	SA 193 B8 (7)	SA 193 B8	SA 193 B7 (7)
24	NUTS	SA 194 2H (7)	SA 194 2H (7)	SA 194 4 (7)(17)	SA 194 G8 (7)	SA 194 G8 (7)	SA 194 G8 (7)	SA 194 G8	SA 194 2H (7)
26	GASKET	Compressed Fibers	Graphite+316 INOX. (9)			Compressed Fibers (12)			
27	GASKET	Compressed Fibers	Graphite+316 INOX. (9)			Compressed Fibers (12)			
28	GASKET	Compressed Fibers	Graphite+316 INOX. (9)			Compressed Fibers (12)			
29	GASKET	Compressed Fibers	Graphite+316 INOX. (9)			Compressed Fibers (12)			
33	BELLOWS	316Ti S.S. (8)	316Ti S.S. (8)	316Ti S.S. (8) (14)	316Ti S.S. (8)	316Ti S.S. (8) (14)	316Ti S.S. (8) (14)	316Ti S.S. (8)	INCONEL 625
34	GASKET	Compressed Fibers	Graphite+316 INOX. (9)			Compressed Fibers (12)			
37	CAM	316 S.S.	316 S.S.	316 S.S.	316 S.S.	316 S.S.	316 S.S.	316 S.S.	316 S.S.
38	BRACKET	C.S. (7)	C.S. (7)	C.S. (7)	C.S. (7)	316 S.S.	316 S.S.	316 S.S.	C.S. (7)
39	LEVER CAP	SA 216 WCB	SA 216 WCB	SA 216 WCB	SA 216 WCB	SA 351 CF8M	SA 351 CF8M	SA 351 CF8M	SA 216 WCB
40	LEVER STEM	A 479 431 (5)	A 479 431 (5)	A 479 431 (5)	A 479 316	A 479 316	A 479 316	A 479 316	A 479 316
41	LEVER	C.S. (7)	C.S. (7)	C.S. (7)	C.S. (7)	C.S. (7)	C.S. (7)	C.S. (7)	C.S. (7)
42	PACKING	Compressed Fibers	Braid Graphite			Compressed Fibers (12)			
43	LEVER SHAFT	A 479 316	A 479 316	A 479 316	A 479 316	A 479 316	A 479 316	A 479 316	A 479 316
44	NUT	C.S. (7)	C.S. (7)	C.S. (7)	C.S. (7)	C.S. (7)	C.S. (7)	C.S. (7)	C.S. (7)
45	PACKING GLAND	C.S. (7)	C.S. (7)	C.S. (7)	C.S. (7)	S.S.	S.S.	S.S.	S.S.
46	PISTON	A 479 431 (6)	A 479 431 (6)	A 479 431 (6)	A 479 431 (6)	A 479 431 (6)	A 479 431 (6)	A 479 316	A 479 431 (6)
47	LOCK WASHER	304 S.S.	304 S.S.	304 S.S.	304 S.S.	304 S.S.	304 S.S.	304 S.S.	304 S.S.
53	NUT	C.S. (7)	C.S. (7)	C.S. (7)	C.S. (7)	S.S.	S.S.	S.S.	S.S.

SUBCLASS		1	2	3	4	10 (Duplex)	11 (Super Duplex)
4	NOZZLE	SA 479 316 (13)	SA 479 316+ST. (13)	SA 479 316+ST. (13)	SA 479 316 (13)	SA 479 S32550 (13)	SA 479 S32760 (13)
5	DISC	SA 479 316	SA 564 630 (10)	SA 479 316+ST.	SA 564 630 (10)	SA 479 S32550	SA 479 S32760

(1) Models with inlet size 1" and 1 1/2", made of Carbon Steel or Stainless Steel bar

(2) Models with inlet size 1" and 1 1/2", made of equivalent bar material

(3) Orifices D-E-F, made of equivalent bar material

(4) For Gas, orifices from M to T, made of equivalent casting material. For Liquid, orifices from P to T, made of equivalent casting material

(5) Quenched and Tempered to 19 ÷ 29 HRC, if necessary. Models with inlet size 1" and 1 1/2", Stem made of A 479 316

(6) Quenched and Tempered to 45 ÷ 50 HRC

(7) Electrolytic bath, Zincate

(8) Bellows endings made of 316L S.S.

(9) Graphite gasket with 316 S.S. reinforcement

(10) H900 Condition, hardness must be between 40 ÷ 47 HRC. For temperatures > -30°C. H1150-M Condition,

hardness must be between 27 ÷ 30 HRC. For temperatures < -30°C.

(11) PaFor temperatures > 300°C, material Inconel X-750 (Tempered)

(12) For temperatures > 232°C and < -29°C, material Graphite with 316 S.S. reinforcement

(13) Models with inlet size from 3" to 8", made of equivalent casting material

(14) For temperatures > 450°C, material Inconel 625

(15) When the spring is unenclosed, carbon or alloy steel is used



■ **Accessories**

TEST-GAG

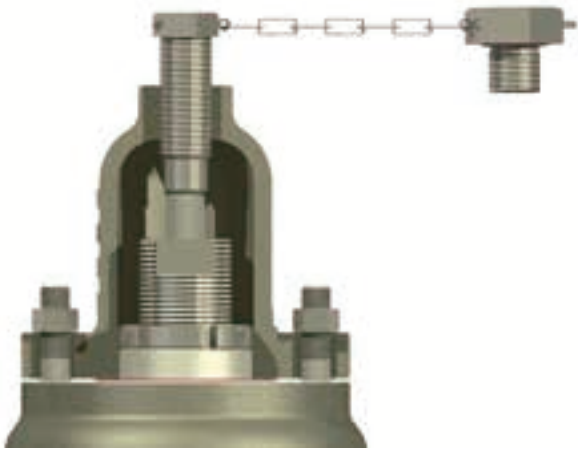

LEVER



O-RING

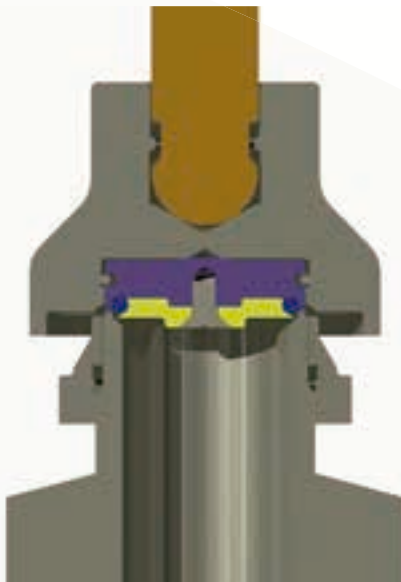

MAGNETIC SENSOR

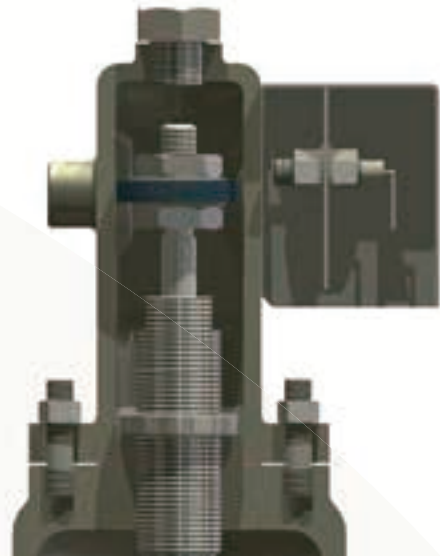

HEATING JACKET

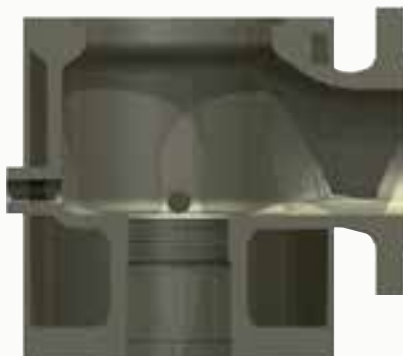

## General Dimensions

*Orifice API 526*	Rating	Inlet	Outlet	Flow Area (cm <sup>2</sup> )	General Dimensions						Standard	Lever Weight - (Kg)
					A	B	C	D	E	F		
<b>D</b>												
150 x 150	1"	2"	0,78	105	114	422	29	90	490	16	17	
300L x 150							32					
300 x 150							34					
600 x 150	1½"	2"	0,78	105	140	492	44	90	556	31	33	
900 x 300							44					
1500 x 300							44					
2500 x 300	1½"	3"	0,78	140	178	518	60	90	582	39	41	
<b>E</b>												
150 x 150	1"	2"	1,43	105	114	422	29	90	490	16	17	
300L x 150							32					
300 x 150							34					
600 x 150	1½"	2"	1,43	105	140	492	44	90	556	31	33	
900 x 300							44					
1500 x 300							44					
2500 x 300	1½"	3"	1,43	140	178	518	60	90	582	39	41	
<b>F</b>												
150 x 150	1½"	2"	2,27	124	121	499	34	90	563	26	27	
300L x 150					152		37					
300 x 150					152		41					
600 x 150	1½"	3"	2,27	124	165	502	44	90	566	34	36	
900 x 300					165		44					
1500 x 300					165		44					
2500 x 300	1½"	3"	2,27	140	178	518	60	90	582	40	42	
<b>G</b>												
150 x 150	1½"	3"	3,63	124	121	499	34	90	563	27	29	
300L x 150					152		37					
300 x 150					152		41					
600 x 150	2"	3"	3,63	124	165	502	44	90	566	35	37	
900 x 300					165		44					
1500 x 300					165		44					
2500 x 300	2"	3"	3,63	156	172	643	70	100	699	56	59	
<b>H</b>												
150 x 150	1½"	3"	5,72	130	124	505	40	90	569	28	29	
300L x 150					616		40					
300 x 150					640		44					
600 x 150	2"	3"	5,72	130	162	643	57	100	699	53	56	
900 x 150					162		57					
1500 x 300					162		57					
<b>J</b>												
150 x 150	2"	3"	9,07	137	124	623	36	120	679	38	41	
300L x 150					721		45					
300 x 150					721		50					
600 x 150	3"	4"	9,07	184	181	714	65	120	782	85	87	
900 x 150					181		65					
1500 x 300					181		65					
<b>K</b>												
150 x 150	3"	4"	13,2	156	162	693	41	120	761	66	69	
300L x 150					184		45					
300 x 150					184		50					
600 x 150	6"	4"	13,2	156	216	803	56	120	871	111	114	
900 x 150					198		56					
1500 x 300					197		66					
<b>L</b>												
150 x 150	3"	4"	20,4	156	165	693	41	120	761	67	69	
300L x 150					179		50					
300 x 150					179		54					
600 x 150	4"	6"	20,4	156	203	869	60	150	971	118	124	
900 x 150					197		60					
1500 x 150					197		69					
<b>M</b>												
150 x 150	4"	6"	26	178	184	871	43	150	974	118	124	
300L x 150					203		54					
300 x 150					203		54					
600 x 150	4"	6"	26	178	222	888	60	150	990	125	131	
900 x 150					197		60					
900 x 150					197		60					
<b>N</b>												
150 x 150	4"	6"	32,2	197	210	881	43	150	983	118	124	
300L x 150					222		54					
300 x 150					222		60					
600 x 150	4"	6"	32,2	197	222	888	60	150	990	125	131	
900 x 150					197		60					
900 x 150					197		60					
<b>P</b>												
150 x 150	4"	6"	46,6	181	229	892	44	150	994	118	124	
300L x 150					225		51					
300 x 150					225		59					
600 x 150	4"	6"	46,6	181	254	916	65	150	1018	125	131	
900 x 150					225		65					
900 x 150					225		65					
<b>Q</b>												
150 x 150	6"	8"	78,5	240	241	1056	45	150	1158	187	193	
300L x 150					241		56					
300 x 150					241		69					
600 x 150	6"	8"	78,5	240	241	1056	45	150	1158	187	193	
900 x 150					241		56					
900 x 150					241		69					
<b>R</b>												
150 x 150	6"	8"	113	240	241	1056	45	150	1158	191	197	
300L x 150					267		56					
300 x 150					267		69					
600 x 150	6"	10"	113	240	267	1056	69	150	1158	234	240	
900 x 150					267		69					
900 x 150					267		69					
<b>T</b>												
150 x 150	8"	10"	184	276	279	1270	51	150	1365	300	314	
300L x 150					279		65					
300 x 150					279		65					
<b>V</b>												
150 x 150	10"	14"	314	330	370	1530	60	220	1555	515	525	
300 x 150										530	540	
<b>W</b>												
150 x 150	12"	16"	452	380	390	1700	60	220	1725	705	715	
300 x 150										720	730	

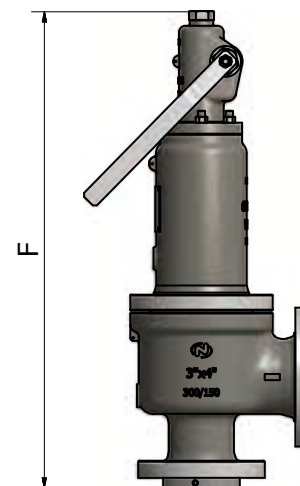
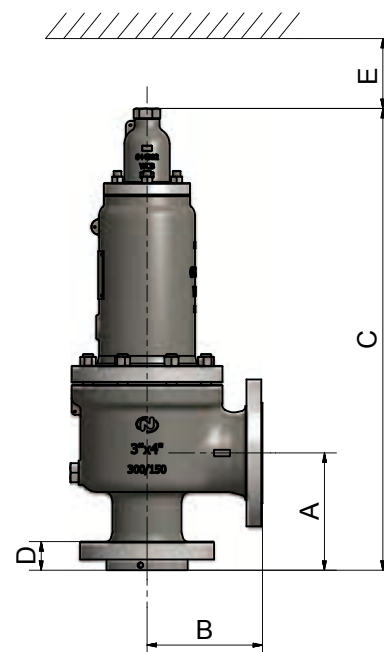



■ **Technical information** / Operating technical characteristics table

SAFETY VALVE MODEL 6400			64GC	64GF 64GP	64LC	64LF 64LP
			conventional	bellows	conventional	bellows
SERVICE			GAS		LIQUID	
DISCHARGE COEFFICIENT (at 10% of overpressure)	(1)(2)	Kd	<b>0,97</b>		<b>0,80</b>	
BLOWDOWN		MAX. MIN.	-7% (4) -2%		-20% (5) -12%	
SUPERIMPOSED BACKPRESSURE	(3)	MAX.	10%	25%	10%	40%
BUILT-UP BACKPRESSURE	(3)	MAX.	15%	40%	15%	50%
SET PRESSURE TOLERANCE	(6)	±	3%			
MINIMUM SET PRESSURE	ASME VIII (bar) EN ISO 4126-1 (bar)		1		0,5	

- (1) or 0,1 bar, whichever is greater
- (2) Certificate test in the National Board Testing Lab.
- (3) Maximum allowable backpressure without overpressure exceeds 10%
- (4) or 0,2 bar, whichever is greater
- (5) or 0,6 bar, whichever is greater
- (6) or ± 0,15 bar, whichever is greater

**OPERATING VALVE GRAPHIC ON TEST BENCH WITH WATER:**

MODEL: 64LF    SIZE: 2" x 3"    ORIFICE: J    SET PRESSURE: 5,6 bar

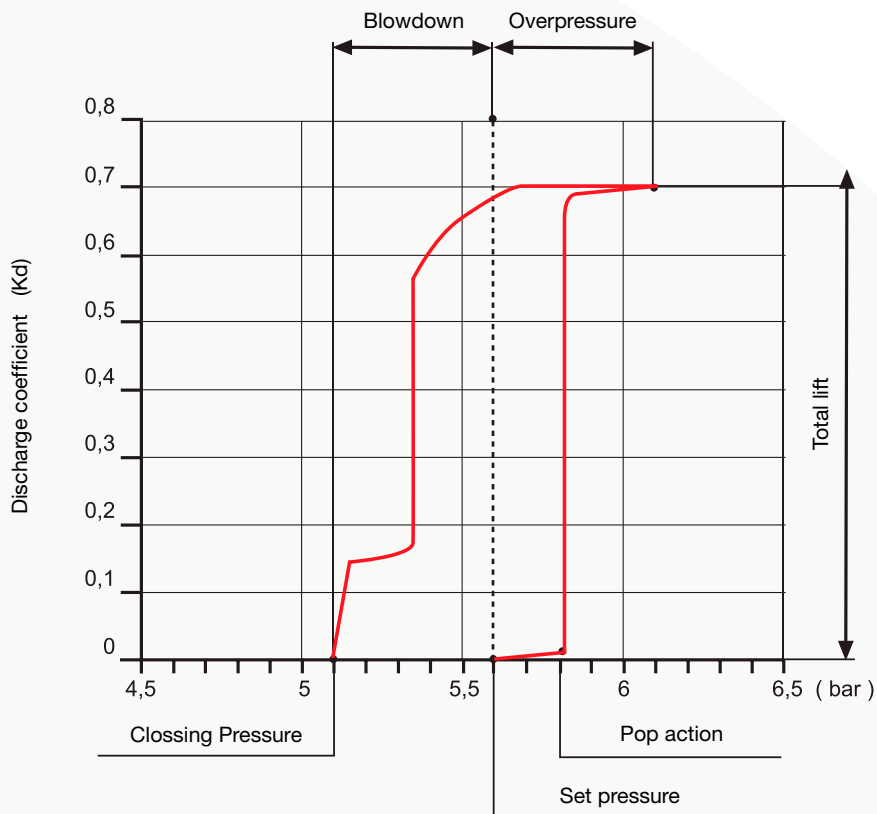

## ■ Technical Information

### Calculation Formulas for the Orifice Area

The following formulas determine the minimum area the safety valve should have to discharge the fluid flow requested

#### Liquids

$$A = \frac{W}{5042 \cdot K \cdot K_3 \cdot K_v \cdot \sqrt{(P - P_b) \cdot E}}$$

#### Gases and Vapours

$$A = \frac{W}{387,2 \cdot C \cdot P \cdot K \cdot K_1 \cdot K_2} \cdot \sqrt{\frac{Z \cdot T}{M}}$$

#### Steam

$$A = \frac{W}{112,7 \cdot C \cdot K \cdot K_1 \cdot K_2} \cdot \sqrt{\frac{V_1}{P}}$$

### Discharge coefficient (K) for safety valves model 6400

Gases and Vapours	K=0,97
Liquids	K=0,80

### Definition of calculation terms

Orifice area	A (cm <sup>2</sup> )
Discharge flow	W (kg/h)
Discharge pressure (set pressure + overpressure + 1.033)	P (kg/cm <sup>2</sup> ) (a)
Set pressure	P1 (kg/cm <sup>2</sup> )
Back pressure	P2 (kg/cm <sup>2</sup> )
Back pressure abs.	Pb (kg/cm <sup>2</sup> )
Over pressure	S (%)
Relieving temperature	T (°K)
Compressibility factor at P and T (use 1 if unknow)	Z
Molecular weight	M
Expansion coefficient as function of (k)	C
Specific heats ratio (use k=1,001 if unknow)	k (cp/cv)
Vapour specific volume at T and T	V <sub>1</sub> (m <sup>3</sup> /kg)
Liquid specific gravity at P and T	E (kg/dm <sup>3</sup> )
Liquid vapour pressure at P and T	P <sub>v</sub> (kg/cm <sup>2</sup> ) (a)
Critical pressure	P <sub>c</sub>
Discharge coefficient	K <sub>1</sub>
Correction coefficient by back pressure for conventional valves if P <sub>b</sub> >0,5P (gases and vapours)	K <sub>2</sub>
Correction coefficient by back pressure for balanced valves if P <sub>2</sub> >0,3P <sub>1</sub> (gases and vapours)	K <sub>3</sub>
Correction coefficient by back pressure for balanced valves if P <sub>2</sub> >0,15P <sub>1</sub> (liquids)	K <sub>v</sub>
Correction coefficient for viscous liquids	K <sub>p</sub>
Correction coefficient due to overpressure different to 25%	



## ■ Technical information / Constants

Constants of some fluids to be used on calculation formulas							
Fluids	M	k = cp / cv (1)	Specific Gravity		Critical Point		
			Gas	Liquid	Pressure	Temp.	Sp. Grav.
			Kg/Nm <sup>3</sup>	Kg/dm <sup>3</sup>	Kg/cm <sup>2</sup>	°C	Kg/dm <sup>3</sup>
Acetylene	26,04	1,26	1,171	0,613	64,7	35,7	0,231
Acetic Acid	60,05	1,15	2,681	1,049	59	321,6	0,351
Hydrochloric Acid	36,47	1,41	1,639		86	51,4	0,61
Nitric Acid				1,502			
Sulfuric Acid				1,834			
Air	28,96	1,41	1,293	0,875	38,4	-140,7	0,31
Ethyl Alcohol	46,07	1,13	2,057	0,789	65,1	243	0,28
Methyl Alcohol	32	1,2	1,429	0,792	102,3	240	0,358
Ammonia	17,03	1,31	0,771	0,68	115,2	132,4	0,235
Sulfur Dioxide	64,06	1,29	2,922	1,434	80,4	157,3	0,524
Argon	39,94	1,67	1,784	1,404	49,6	-122,4	0,531
Venezene	78,11	1,12	3,487	0,879	49,6	288,6	0,305
Butane - n	58,12	1,09	2,703	0,6	37,2	153,2	
Butane - iso	58,12	1,1	2,668	0,595	37,7	133,7	
Chlorine	70,91	1,35	3,22	1,558	78,5	144	0,573
Carbon Dioxide	44,01	1,3	1,977	1,101	75	31	0,46
Dowtherm - A	165	1,05	7,365	0,997			
Ethane	30,07	1,19	1,356	0,546	50,6	35	0,21
Ethylene	28,05	1,24	1,261	0,568	52,4	9,5	0,216
Freon - 12	120,92	1,14	5,397	1,486			
Freon - 22	86,48	1,18	3,86	1,419			
Fuel Oil				0,899			
Natural Gas	19	1,27	0,853				
Gasoline				0,75			
Helium	4	1,66	0,179	0,125	2,33	-267,9	0,069
Heptane - n	100,2	1,05	4,473		27,8	266,8	0,234
Hexane - n	86,17	1,06	3,847	0,659	30,8	234,8	0,234
Hydrogen	2,02	1,41	0,09	0,071	13,2	-239,9	0,031
Kerosene				0,815			
Metane	16,04	1,31	0,717	0,415	47,2	-82,5	0,162
Nitrogen	28,02	1,4	1,251	0,81	34,6	-147,1	0,311
Octane - n	114,22	1,05	5,099	0,707	25,5	296,2	0,233
Nitrous Oxide	44,02	1,3	1,978	1,226	74	36,5	0,46
Oxygen	32	1,4	1,429	1,131	51,4	-118,8	0,43
Pentane - n	72,15	1,07	3,221	0,631	34,1	197	0,232
Propane	44,09	1,13	2,019	0,585	43,3	96,8	0,226
Carbon Disulphide	76,13	1,21	3,398	1,263	77,5	277	0,441

(1) Values of k at 15°C and ° Atm.

## ■ Technical information / Values of K y and C

### Values of $k=cp/cv$ for Steam

P <sub>1</sub> bar abs		P <sub>1</sub> bar abs											
		1	3	5	10	15	20	30	40	50	60	70	80
T1 °C (°K)													
200 (473,15)		1,31	1,31	1,31	1,30	1,29							
250 (523,15)		1,31	1,31	1,30	1,30	1,29	1,28						
300 (573,15)		1,30	1,30	1,30	1,29	1,29	1,29	1,29	1,28	1,27	1,27	1,26	1,26
350 (623,15)		1,30	1,30	1,29	1,29	1,29	1,29	1,29	1,28	1,28	1,28	1,27	1,27
400 (673,15)		1,29	1,29	1,29	1,29	1,29	1,29	1,28	1,28	1,28	1,28	1,28	1,28
450 (723,15)		1,28	1,28	1,28	1,28	1,28	1,28	1,28	1,28	1,28	1,28	1,28	1,28
500 (773,15)		1,28	1,28	1,28	1,28	1,28	1,28	1,28	1,28	1,28	1,28	1,28	1,28
550 (823,15)		1,27	1,27	1,27	1,27	1,27	1,27	1,27	1,27	1,27	1,27	1,28	1,28
600 (873,15)		1,27	1,27	1,27	1,27	1,27	1,27	1,27	1,27	1,27	1,27	1,27	1,27
650 (923,15)		1,26	1,26	1,26	1,26	1,26	1,26	1,26	1,26	1,26	1,26	1,27	1,27
700 (973,15)		1,26	1,26	1,26	1,26	1,26	1,26	1,26	1,26	1,26	1,26	1,26	1,26
Saturated Steam	T1 °C	99,63	133,54	151,85	179,88	198,28	212,37	233,84	250,33	263,92	275,56	285,8	294,98
	°K	372,78	406,69	425	453,03	471,43	485,52	506,99	523,48	537,07	548,71	558,95	568,13
	k = cp/cv	1,32	1,31	1,31	1,3	1,29	1,29	1,28	1,27	1,27	1,26	1,26	1,25

P <sub>1</sub> bar abs		P <sub>1</sub> bar abs											
		90	100	120	140	160	180	200	220	240	260	280	300
T1 °C (°K)													
200 (473,15)													
250 (523,15)													
300 (573,15)													
350 (623,15)		1,27	1,26	1,25	1,25	1,25							
400 (673,15)		1,28	1,28	1,28	1,28	1,28	1,28	1,28	1,30	1,31	1,32	1,33	1,35
450 (723,15)		1,28	1,28	1,29	1,29	1,29	1,29	1,30	1,31	1,32	1,34	1,36	1,37
500 (773,15)		1,28	1,28	1,29	1,29	1,30	1,30	1,31	1,32	1,33	1,34	1,35	1,36
550 (823,15)		1,28	1,28	1,28	1,29	1,29	1,29	1,30	1,31	1,31	1,32	1,33	1,34
600 (873,15)		1,27	1,27	1,28	1,28	1,29	1,29	1,30	1,30	1,31	1,32	1,32	1,32
650 (923,15)		1,27	1,27	1,27	1,28	1,28	1,28	1,29	1,29	1,30	1,30	1,30	1,31
700 (973,15)		1,26	1,26	1,27	1,27	1,27	1,27	1,28	1,29	1,29	1,29	1,30	1,30
Saturated Steam	T1 °C	303,31	310,96	324,64	336,63	347,32	356,96	365,71	373,68				
	°K	576,46	584,11	597,79	609,78	620,47	630,11	638,86	646,83				
	k = cp/cv	1,25	1,25	1,24	1,24	1,24	1,25	1,27	1,3				

### Values of C as function of k

k	C	k	C	k	C	k	C
0,40	0,417	1,01	0,609	1,40	0,685	1,82	0,747
0,45	0,439	1,02	0,611	1,42	0,688	1,84	0,750
0,50	0,459	1,04	0,615	1,44	0,691	1,86	0,752
0,55	0,478	1,06	0,620	1,46	0,695	1,88	0,755
0,60	0,496	1,08	0,624	1,48	0,698	1,90	0,758
0,65	0,512	1,10	0,628	1,50	0,701	1,92	0,760
0,70	0,528	1,12	0,633	1,52	0,704	1,94	0,763
0,75	0,543	1,14	0,637	1,54	0,707	1,96	0,765
0,80	0,557	1,16	0,641	1,56	0,710	1,98	0,767
0,82	0,562	1,18	0,645	1,58	0,713	2,00	0,770
0,84	0,567	1,20	0,649	1,60	0,716	2,10	0,781
0,86	0,573	1,22	0,652	1,62	0,719	2,20	0,793
0,88	0,578	1,24	0,656	1,64	0,722	2,30	0,803
0,90	0,583	1,26	0,660	1,66	0,725	2,40	0,813
0,92	0,588	1,28	0,664	1,68	0,728	2,50	0,823
0,94	0,593	1,30	0,667	1,70	0,731	2,60	0,832
0,96	0,597	1,32	0,671	1,72	0,734	2,70	0,841
0,98	0,602	1,34	0,674	1,74	0,736	2,80	0,850
0,99	0,604	1,36	0,678	1,78	0,742	2,90	0,858
1,001	0,607	1,38	0,681	1,8	0,745	3,00	0,866



■ **Technical information** / Correction coefficient charts

**Correction Coefficients  $K_1, K_2, K_3, K_p$**

Correction Coefficient by back pressure for conventional valves  $K_1$  (Gases and Vapours)

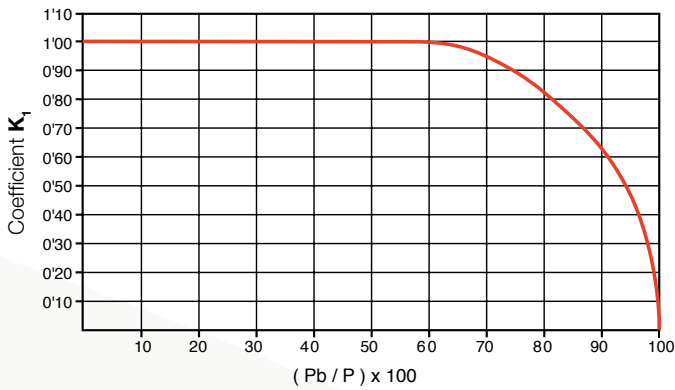

Critical pressure coefficient  $rc$  (Water)

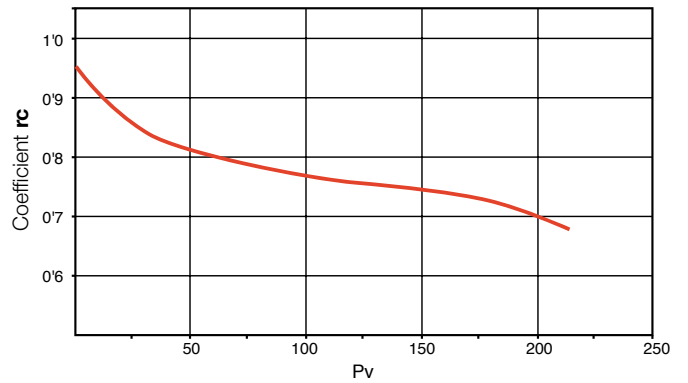

Correction Coefficient by back pressure for balanced valves  $K_2$  (Gases and Vapours)

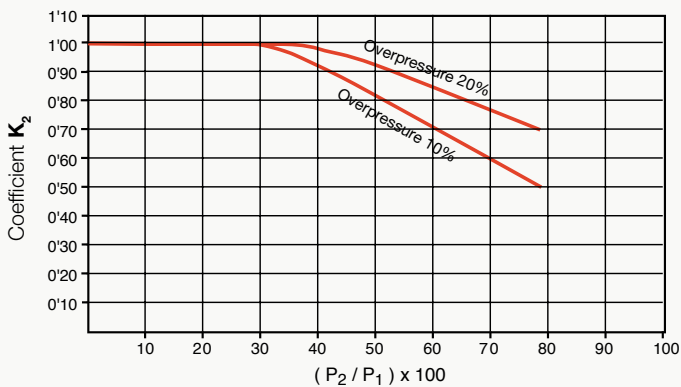

Critical pressure coefficient  $rc$  (Liquids)

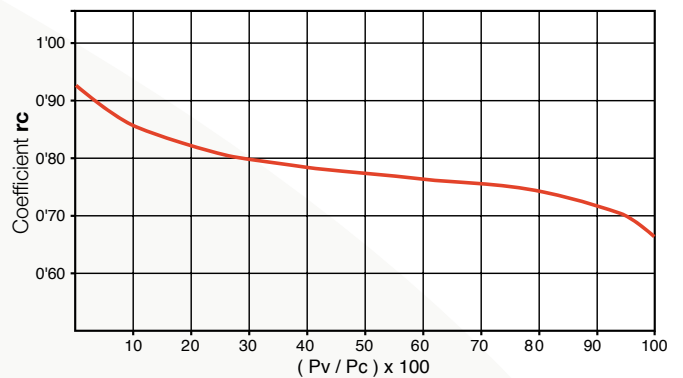

Correction Coefficient by back pressure for balanced valves  $K_3$  (Liquids)

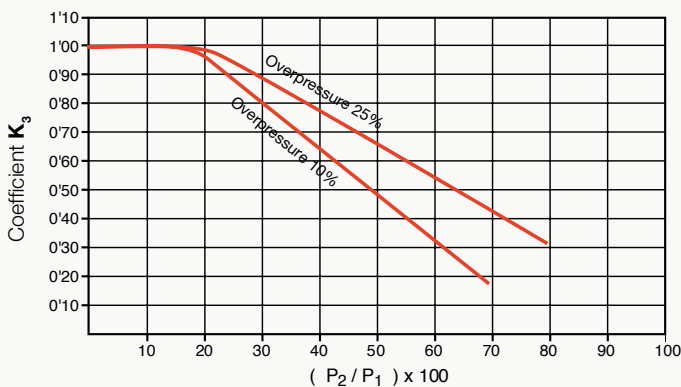

$K_v$  Viscosity Correction Factor

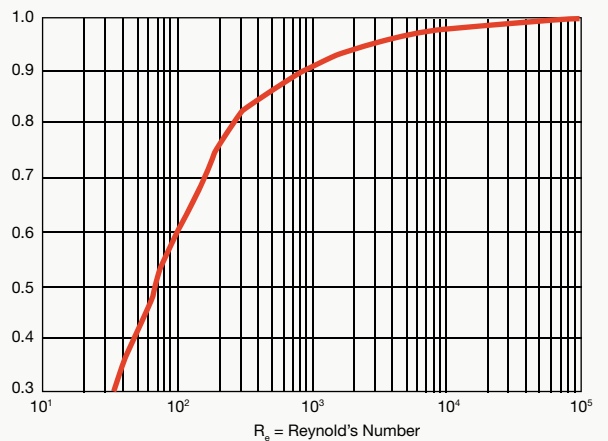



## ■ Technical information

### Gases discharge flow / Capacity chart - Air

$$A = \frac{W}{387,2 \cdot C \cdot P \cdot K \cdot K_1 \cdot K_2} \cdot \sqrt{\frac{Z \cdot T}{M}}$$

Values used in the formulas														
Flow		Nm <sup>3</sup> /h	Compressibility factor Z:						1	Temperature:				15° C
Overpressure		10% (*)	Specific Heat Ratio K:						1,41	Discharge coefficient derated:				0,970
P <sub>1</sub>	D	E	F	G	H	J	K	L	M	N	P	Q	R	T
Kg/cm <sup>2</sup>	0,78	1,43	2,27	3,63	5,72	9,07	13,2	20,4	26	32,2	46,6	78,5	113	184
0,5	77	141	224	358	565	895	1303	2013	2566	3178	4599	7748	11153	18161
1,0	99	182	289	461	727	1153	1678	2593	3305	4093	5924	9979	14365	23391
1,5	121	222	353	565	890	1411	2053	3173	4044	5009	7249	12211	17578	28622
2,0	144	263	418	668	1052	1669	2429	3753	4784	5924	8574	14443	20790	33853
2,5	168	308	488	781	1230	1927	2804	4333	5592	6926	10023	16884	24304	39575
3,0	192	352	559	894	1409	2184	3179	4913	6405	7932	11480	19339	27838	45329
3,5	217	397	630	1008	1588	2442	3554	5493	7218	8939	12937	21793	31371	51082
4,0	241	442	701	1121	1767	2700	3930	6073	8031	9946	14394	24248	34905	56836
4,5	265	486	772	1235	1946	2958	4305	6653	8844	10953	15851	26703	38438	62590
5,0	290	531	843	1348	2125	3216	4680	7233	9657	11960	17309	29157	41972	68343
6,0	338	621	985	1575	2482	3731	5430	8393	11283	13974	20223	34067	49039	79851
7,0	387	710	1127	1802	2840	4247	6181	9552	12909	15988	23137	38976	56106	91358
8,0	436	799	1269	2029	3198	4763	6931	10712	14535	18001	26052	43885	63173	102865
9,0	485	889	1411	2256	3555	5278	7682	11872	16161	20015	28966	48795	70240	114373
10,0	534	978	1553	2483	3913	5794	8432	13032	17787	22029	31880	53704	77307	125880
11,0	582	1068	1695	2710	4271	6310	9183	14192	19413	24043	34795	58614	84374	137387
12,0	631	1157	1837	2937	4629	6825	9933	15352	21039	26057	37709	63523	91441	148895
13,0	680	1247	1979	3164	4986	7341	10684	16511	22666	28070	40624	68432	98508	160402
14,0	729	1336	2121	3391	5344	7857	11434	17671	24292	30084	43538	73342	105575	171909
15,0	778	1425	2263	3618	5702	8372	12185	18831	25918	32098	46452	78251	112642	183417
16,0	826	1515	2405	3846	6060	8888	12935	19991	27544	34112	49367	83161	119709	194924
17,0	875	1604	2547	4073	6417	9404	13686	21151	29170	36126	52281	88070	126776	206432
18,0	924	1694	2689	4300	6775	9919	14436	22311	30796	38139	55195	92979	133843	217939
19,0	973	1783	2831	4527	7133	10435	15187	23470	32422	40153	58110	97889	140910	229446
20,0	1021	1873	2973	4754	7491	10951	15937	24630	34048	42167	61024	102798	147977	240954
25,0	1265	2320	3682	5889	9279	13529	19690	30429	42178	52236	75596	127345	183312	
30,0	1509	2767	4392	7024	11068	16107	23442	36229	50308	62305	90168	151892	218647	
35,0	1753	3214	5102	8159	12856	18686	27194	42028	58438	72374	104740	176439		
40,0	1997	3661	5812	9294	14645	21264	30947	47827	66569	82443	119311	200986		
45,0	2241	4108	6522	10429	16434	23843	34699	53626	74699	92512	133883	225533		
50,0	2485	4556	7232	11564	18222	26421	38452	59425	82829	102581	148455			
55,0	2729	5003	7941	12699	20011	28999	42204	65224	90959	112649	163027			
60,0	2973	5450	8651	13834	21800	31578	45956	71024	99089	122718	177599			
65,0	3217	5897	9361	14970	23588	34156	49709	76823	107220	132787	192170			
70,0	3460	6344	10071	16105	25377	36734	53461	82622	115350	142856	206742			
75,0	3704	6791	10781	17240	27166	39313	57214	88421	123480	152925	221314			
80,0	3948	7239	11491	18375	28954	41891	60966	94220	131610	162994				
85,0	4192	7686	12200	19510	30743	44469	64718	100019	139740	173063				
90,0	4436	8133	12910	20645	32532	47048	68471	105818	147871	183132				
95,0	4680	8580	13620	21780	34320	49626	72223	111618	156001					
100,0	4924	9027	14330	22915	36109	52204	75976	117417	164131					
110,0	5412	9922	15750	25185	39686	57361	83480	153373	180391					
120,0	5900	10816	17169	27456	43263	62518	90985							
130,0	6387	11710	18589	29726	46841	67675	98490							
140,0	6875	12604	20009	31996	50418	72831	105995							
150,0	7363	13499	21428	34266	53995	77988	113500							
160,0	7851	14393	22848	36536	57573	83145	121004							
170,0	8339	15287	24268	38807	61150	88301	128509							
180,0	8826	16182	25687	41077	64727	93458	136014							
190,0	9314	17076	27107	43347	68304	98615								
200,0	9802	17970	28526	45617	71882	103772								
220,0	10778	19759	31366	50158	79036	114085								
240,0	11753	21548	34205	54698										
260,0	12729	23336	37044	59238										
280,0	13705	25125	39884	63779										
300,0	14680	26914	42723											
320,0	15656	28702	45562											
340,0	16631	30491	48402											

(\*) Minimum overpressure 0,2 bar g  
It is recommended, if possible, selecting the orifice by applying the calculation formulas.  
These tables can be useful when a quick estimation of the orifice is required.  
Atmospheric pressure will be considered



## ■ Technical information

### Steam discharge flow / Capacity chart - steam

$$A = \frac{W}{112,7 \cdot C \cdot K \cdot K_1 \cdot K_2} \cdot \sqrt{\frac{V_1}{P}}$$

Flow:		Kg/h		The results shown correspond to calculations for saturated steam For superheated steam, multiply by Ks Minimum overpressure 0,2 bar g											
Overpressure:		10%													
Discharge coefficient derated:		0,873													
P <sub>1</sub>	D	E	F	G	H	J	K	L	M	N	P	Q	R	T	
Kg/cm <sup>2</sup>	0,78	1,43	2,27	3,63	5,72	9,07	13,2	20,4	26	32,2	46,6	78,5	113	184	
0,5	49	89	142	227	357	566	824	1273	1623	2010	2909	4900	7054	11486	
1	55	101	161	257	405	643	935	1446	1842	2282	3302	5562	8007	13038	
1,5	85	156	248	396	624	990	1440	2226	2837	3513	5084	8565	12329	20075	
2	93	170	269	431	679	1076	1566	2421	3085	3821	5530	9315	13409	21834	
2,5	121	222	352	563	888	1408	2049	3166	4035	4998	7233	12184	17539	28559	
3	130	238	377	603	950	1507	2193	3389	4319	5349	7741	13040	18771	30565	
3,5	157	289	458	733	1155	1831	2664	4117	5248	6499	9406	15844	22808	37138	
4	166	304	483	773	1218	1931	2810	4343	5535	6855	9921	16713	24058	39174	
4,5	194	355	563	901	1419	2251	3276	5062	6452	7991	11564	19481	28042	45662	
5	202	371	589	941	1483	2352	3423	5290	6742	8350	12084	20356	29303	47714	
6	237	434	689	1102	1736	2753	4007	6192	7892	9774	14146	23829	34301	55854	
7	272	499	793	1267	1997	3167	4608	7122	9077	11242	16269	27406	39451	64239	
8	308	564	896	1433	2258	3580	5210	8052	10262	12710	18394	30985	44602	72627	
9	343	630	999	1598	2518	3993	5811	8981	11446	14176	20515	34559	49747	81004	
10	379	694	1102	1763	2778	4405	6410	9907	12626	15637	22630	38122	54876	89356	
11	414	759	1205	1927	3037	4816	7008	10831	13804	17096	24742	41679	59996	97693	
12	449	824	1308	2091	3296	5226	7605	11754	14980	18552	26849	45229	65106	106014	
13	485	889	1411	2256	3555	5636	8203	12677	16157	20010	28959	48783	70222	114344	
14	520	953	1513	2420	3813	6047	8800	13601	17334	21468	31068	52335	75336	122671	
15	555	1018	1616	2584	4072	6457	9397	14522	18508	22922	33173	55881	80440	130982	
16	591	1083	1719	2749	4332	6869	9997	15450	19691	24387	35293	59452	85581	139353	
17	626	1147	1821	2912	4589	7277	10591	16367	20860	25835	37388	62982	90662	147627	
18	661	1212	1925	3078	4850	7690	11192	17297	22045	27302	39511	66559	95810	156010	
19	696	1277	2027	3241	5107	8099	11786	18215	23216	28752	41610	70094	100899	164296	
20	732	1342	2130	3406	5366	8509	12384	19139	24393	30209	43719	73647	106014		
25	909	1667	2646	4231	6667	10571	15385	23776	30303	37529	54313	91493	131703		
30	1087	1993	3164	5060	7973	12643	18399	28435	36241	44883	64955	109421	157510		
35	1256	2303	3656	5847	9213	14610	21262	32859	41880	51866	75061	126444			
40	1435	2632	4178	6681	10527	16692	24293	37543	47849	59260	85761	144468			
45	1606	2944	4673	7473	11776	18672	27175	41998	53526	66290	95936	161608			
50	1787	3276	5200	8315	13103	20776	30237	46730	59557	73759	106745				
55	1970	3612	5733	9168	14446	22907	33338	51522	65666	81324	117693				
60	2154	3949	6269	10025	15796	25047	36453	56336	71801	88923	128689				
65	2308	4231	6717	10741	16925	26838	39059	60364	76934	95280	137889				
70	2492	4569	7254	11599	18278	28983	42180	65187	83081	102893	148907				
75	2664	4885	7754	12400	19539	30983	45090	69685	88814	109993	159183				
80	2852	5229	8301	13274	20917	33168	48270	74600	95078	117751					
85	3045	5583	8863	14173	22333	35413	51538	79649	101513	125720					
90	3238	5936	9423	15068	23743	37649	54793	84680	107925						
95	3426	6281	9970	15944	25123	39837	57977	89600	114196						
100	3623	6642	10543	16859	26566	42125	61306	94746	120755						
110	3984	7304	11594	18541	29216	46326	67421	104196	132798						
120	4401	8068	12808	20481	32273	51175	74477								
130	4723	8658	13744	21978	34632	54915	79920								
140	5166	9470	15034	24040	37882	60068	87420								
150	5536	10149	16111	25763	40596	64371	93683								
160	6019	11035	17516	28011	44138	69988	101857								
170	6407	11747	18647	29818	46987	74505	108431								
180	6953	12748	20236	32360	50992	80856	117673								
190	7418	13600	21588	34523	54399	86259									
200	8079	14812	23513	37600	59249	93948									
220	9498	17413	27642	44203	69653	110447									

(\*)It is recommended, if possible, selecting the orifice by applying the calculation formulas. These tables can be useful when a quick estimation of the orifice is required. Atmospheric pressure will be considered





## ■ Technical information

### Liquids discharge flow / Capacity chart - liquids

$$A = \frac{W}{5042 \cdot K \cdot K_3 \cdot K_v \cdot \sqrt{(P - P_b) \cdot E}}$$

Flow:		m³/h		The results shown correspond to calculations for water For different relative densities of water to 1, multiply by Kg Minimum overpressure 0,2 bar g											
Overpressure:		10%													
Discharge coefficient derated:		0,800													
P <sub>1</sub>	D	E	F	G	H	J	K	L	M	N	P	Q	R	T	
Kg/cm²	0,78	1,43	2,27	3,63	5,72	9,07	13,2	20,4	26	32,2	46,6	78,5	113	184	
0,5	2,37	4,34	6,89	11,03	17,37	27,55	40,09	61,96	78,97	97,80	141,54	238,43	343,21	558,86	
1	3,10	5,69	9,03	14,44	22,75	36,07	52,49	81,13	103,39	128,05	185,32	312,17	449,37	731,72	
1,5	3,69	6,77	10,74	17,18	27,07	42,93	62,48	96,56	123,06	152,41	220,57	371,56	534,86	870,92	
2	4,20	7,70	12,22	19,55	30,80	48,84	71,08	109,84	140,00	173,38	250,92	422,68	608,45	990,75	
2,5	4,70	8,61	13,67	21,85	34,43	54,60	79,46	122,81	156,52	193,85	280,54	472,58	680,27	1107,69	
3	5,14	9,43	14,97	23,94	37,72	59,81	87,05	134,53	171,46	212,35	307,31	517,68	745,20	1213,42	
3,5	5,56	10,19	16,17	25,86	40,74	64,61	94,02	145,31	185,20	229,36	331,93	559,16	804,90	1310,64	
4	5,94	10,89	17,29	27,64	43,56	69,07	100,52	155,34	197,99	245,20	354,85	597,77	860,48	1401,13	
4,5	6,30	11,55	18,33	29,32	46,20	73,26	106,61	164,77	210,00	260,07	376,38	634,03	912,68	1486,13	
5	6,64	12,17	19,33	30,90	48,70	77,22	112,38	173,68	221,36	274,14	396,74	668,32	962,04	1566,51	
6	7,27	13,34	21,17	33,85	53,35	84,59	123,11	190,26	242,48	300,31	434,60	732,11	1053,87	1716,03	
7	7,86	14,41	22,87	36,57	57,62	91,37	132,97	205,50	261,91	324,37	469,43	790,77	1138,31	1853,53	
8	8,40	15,40	24,45	39,09	61,60	97,68	142,15	219,69	279,99	346,76	501,84	845,37	1216,90	1981,50	
9	8,91	16,33	25,93	41,46	65,34	103,60	150,77	233,01	296,98	367,80	532,28	896,65	1290,72	2101,70	
10	9,39	17,22	27,33	43,71	68,87	109,20	158,93	245,62	313,04	387,69	561,07	945,15	1360,54	2215,39	
11	9,85	18,06	28,67	45,84	72,23	114,53	166,69	257,61	328,32	406,62	588,46	991,28	1426,94	2323,52	
12	10,29	18,86	29,94	47,88	75,44	119,63	174,10	269,06	342,92	424,70	614,62	1035,36	1490,39	2426,83	
13	10,71	19,63	31,16	49,83	78,52	124,51	181,21	280,05	356,92	442,04	639,72	1077,64	1551,25	2525,93	
14	11,11	20,37	32,34	51,71	81,49	129,21	188,05	290,62	370,40	458,72	663,87	1118,32	1609,81	2621,28	
15	11,50	21,09	33,47	53,53	84,35	133,75	194,65	300,82	383,40	474,82	687,17	1157,57	1666,31	2713,28	
16	11,88	21,78	34,57	55,28	87,11	138,13	201,03	310,69	395,97	490,40	709,70	1195,53	1720,96	2802,27	
17	12,24	22,45	35,64	56,99	89,80	142,38	207,22	320,25	408,16	505,49	731,55	1232,33	1773,92	2888,51	
18	12,60	23,10	36,67	58,64	92,40	146,51	213,23	329,53	419,99	520,14	752,76	1268,05	1825,35	2972,25	
19	12,95	23,73	37,67	60,24	94,93	150,53	219,07	338,56	431,50	534,40	773,38	1302,80	1875,37		
20	13,28	24,35	38,65	61,81	97,40	154,44	224,76	347,36	442,71	548,28	793,47	1336,65	1924,09		
25	14,85	27,22	43,21	69,10	108,89	172,67	251,29	388,36	494,97	613,00	887,13	1494,42	2151,20		
30	16,27	29,82	47,34	75,70	119,29	189,15	275,27	425,42	542,21	671,50	971,80	1637,05			
35	17,57	32,21	51,13	81,77	128,84	204,30	297,33	459,51	585,65	725,31	1049,67	1768,22			
40	18,78	34,43	54,66	87,41	137,74	218,41	317,86	491,24	626,09	775,39	1122,14	1890,30			
45	19,92	36,52	57,98	92,71	146,09	231,66	337,14	521,04	664,07	822,42	1190,21	2004,97			
50	21,00	38,50	61,11	97,73	154,00	244,19	355,38	549,22	699,99	866,91	1254,59				
55	22,02	40,38	64,10	102,50	161,51	256,11	372,72	576,03	734,15	909,22	1315,83				
60	23,00	42,17	66,95	107,06	168,70	267,49	389,30	601,64	766,80	949,65	1374,34				
65	23,94	43,90	69,68	111,43	175,58	278,42	405,19	626,21	798,11	988,43	1430,46				
70	24,85	45,55	72,31	115,63	182,21	288,93	420,49	649,85	828,24	1025,74	1484,45				
75	25,72	47,15	74,85	119,69	188,61	299,07	435,25	672,66	857,31	1061,74	1536,56				
80	26,56	48,70	77,30	123,62	194,79	308,88	449,52	694,72	885,42	1096,56					
85	27,38	50,20	79,68	127,42	200,79	318,38	463,36	716,10	912,67	1130,31					
90	28,17	51,65	81,99	131,12	206,61	327,61	476,79	736,86	939,13	1163,08					
95	28,95	53,07	84,24	134,71	212,27	336,59	489,85	757,05	964,87						
100	29,70	54,45	86,43	138,21	217,78	345,33	502,58	776,72	989,93						
110	31,15	57,10	90,65	144,96	228,41	362,19	527,11	814,63	1038,25						
120	32,53	59,64	94,68	151,40	238,57	378,29	550,55								
130	33,86	62,08	98,54	157,58	248,31	393,74	573,03								
140	35,14	64,42	102,26	163,53	257,69	408,60	594,66								
150	36,37	66,68	105,85	169,27	266,73	422,95	615,53								
160	37,57	68,87	109,32	174,82	275,48	436,82	635,72								
170	38,72	70,99	112,69	180,20	283,96	450,26	655,28								
180	39,84	73,05	115,96	185,43	292,19	463,31	674,28								
190	40,94	75,05	119,13	190,51	300,20	476,01									
200	42,00	77,00	122,23	195,46	307,99	488,38									
220	44,05	80,76	128,19	205,00	323,03	512,21									
240	46,01	84,35	133,89	214,11											
260	47,89	87,79	139,36	222,86											
280	49,69	91,11	144,62	231,27											
300	51,44	94,30	149,70												
320	53,13	97,40	154,61												
340	54,76	100,39	159,37												

Correction coeff. Spec. Grvty.	
D	Kg
0,20	2,240
0,30	1,825
0,40	1,580
0,50	1,414
0,60	1,320
0,70	1,195
0,80	1,117
0,84	1,091
0,88	1,066
0,92	1,043
0,96	1,021
1,00	1,000
1,04	0,981
1,08	0,962
1,12	0,945
1,16	0,928
1,20	0,913
1,30	0,877



■ **Technical information** / Correction factors

DENS.	Kg	° C	Kt	K	Kc	P <sub>1</sub> (Kg/cm <sup>2</sup> )	T (° C)	0,99	0,97	0,93	0,89	0,85	0,81	0,77
								Superheated steam (° C)						
Ks														
0,20	2,240	-29	1,087	1,01	1,000	0,5	111	136	166	238	299	354,5	417,5	493,5
0,30	1,825	-23	1,075	1,02	1,010	1	119,5	131	170	239	298	353	416,5	493
0,40	1,580	-18	1,063	1,04	1,016	1,5	127	142	174	240	296	351	416	492
0,50	1,414	-12	1,052	1,06	1,022	2	133	146	177	240,5	295	350	414,5	491,8
0,60	1,320	-7	1,041	1,08	1,029	2,5	138	151	179	241	294	349,5	413,5	491,5
0,70	1,195	-1	1,030	1,10	1,033	3	143	156	183	242	293,5	348,5	412	491
0,80	1,117	4	1,020	1,12	1,044	3,5	147	161	185	243	293	347,5	411	491
0,82	1,104	10	1,010	1,14	1,051	4	151	164	188	244	292,5	346,5	410	490,8
0,84	1,091	15	1,000	1,16	1,057	4,5	154,5	168	190	245	292	346	410	490,5
0,86	1,078	21	0,9905	1,18	1,063	5	158	171	193	246	291,5	345	410	490,5
0,88	1,066	27	0,9813	1,20	1,070	6	164	176	198	248	295	344,5	409,5	490,2
0,90	1,055	32	0,9723	1,22	1,076	7	169,5	182	202	251	290,5	344	409	490
0,92	1,043	38	0,9636	1,24	1,083	8	174,5	186	206	253	291	344	408	489,5
0,94	1,031	43	0,9552	1,26	1,089	9	179	191	210	256	292	344,5	407,5	489
0,96	1,021	49	0,9469	1,28	1,095	10	183		214	258	293,5	345,5	407	489
0,98	1,010	54	0,9388	1,30	1,102	11	187		217	261	295,5	346	407	489
1,00	1,000	60	0,9310	1,32	1,108	12	190,5		220	263	298	346,5	407	488,5
1,02	0,990	66	0,9233	1,34	1,113	13	194		224	265	300	347	406,7	488
1,04	0,981	71	0,9158	1,36	1,118	14	197,5		227	267	301,5	348	406,5	488
1,06	0,971	82	0,9014	1,38	1,124	15	200,5		229	268,5	303	349	406	488
1,08	0,962	93	0,8876	1,40	1,130	16	203,5		232	270,5	304,5	350	406	488
1,10	0,953	104	0,8746	1,42	1,136	17	206		234	272	306	351	406	487,8
1,12	0,945	116	0,8619	1,44	1,141	18	209		236	274	307,5	352	406	487,8
1,14	0,937	127	0,8498	1,46	1,146	19	211,5		239	275,5	309	352,5	406,5	487,8
1,16	0,928	138	0,8383	1,48	1,152	20	214		241	277,5	310,5	353	406,7	487,8
1,18	0,921	149	0,8272	1,50	1,157	25	225		251	286	317	359	410	491
1,20	0,913	160	0,8165	1,52	1,162	30	234,5		259	292	323	365,5	415	493
1,25	0,895	171	0,8062	1,54	1,168	35	243		267	298	329	371	420	496
1,30	0,877	182	0,7963	1,56	1,172	40	250,5		274	305	334	377	424	500
1,35	0,861	193	0,7868	1,58	1,177	45	257,5		280	310	340	382	429	503
1,40	0,845	204	0,7776	1,60	1,182	50	264		286	315	346	387	433	506
1,45	0,830	260	0,7360	1,62	1,187	55	270		291	320	351	391	437	510
1,50	0,817	316	0,7005	1,64	1,193	60	275		296	324	355	396	441	512
1,55	0,803	371	0,6695	1,66	1,197	65	281		301	329	360	400	441	515
1,60	0,791	427	0,6425	1,68	1,202	70	286		306	333	364	404	449	518
1,65	0,779	480	0,6183	1,70	1,207									
1,70	0,768	538	0,5968	2,00	1,270									
1,75	0,756			2,20	1,308									
1,80	0,745													
1,90	0,725													
2,00	0,707													
2,10	0,690													
2,20	0,674													
2,30	0,659													
2,40	0,645													
2,50	0,633													

NOTE:  
In case of using the flow charts on the previous pages for orifice determination, it will be necessary to apply the corrector factors here indicated for fluids or other working conditions different than those for which it has been calculated the mentioned charts.



## Technical information / API selection chart

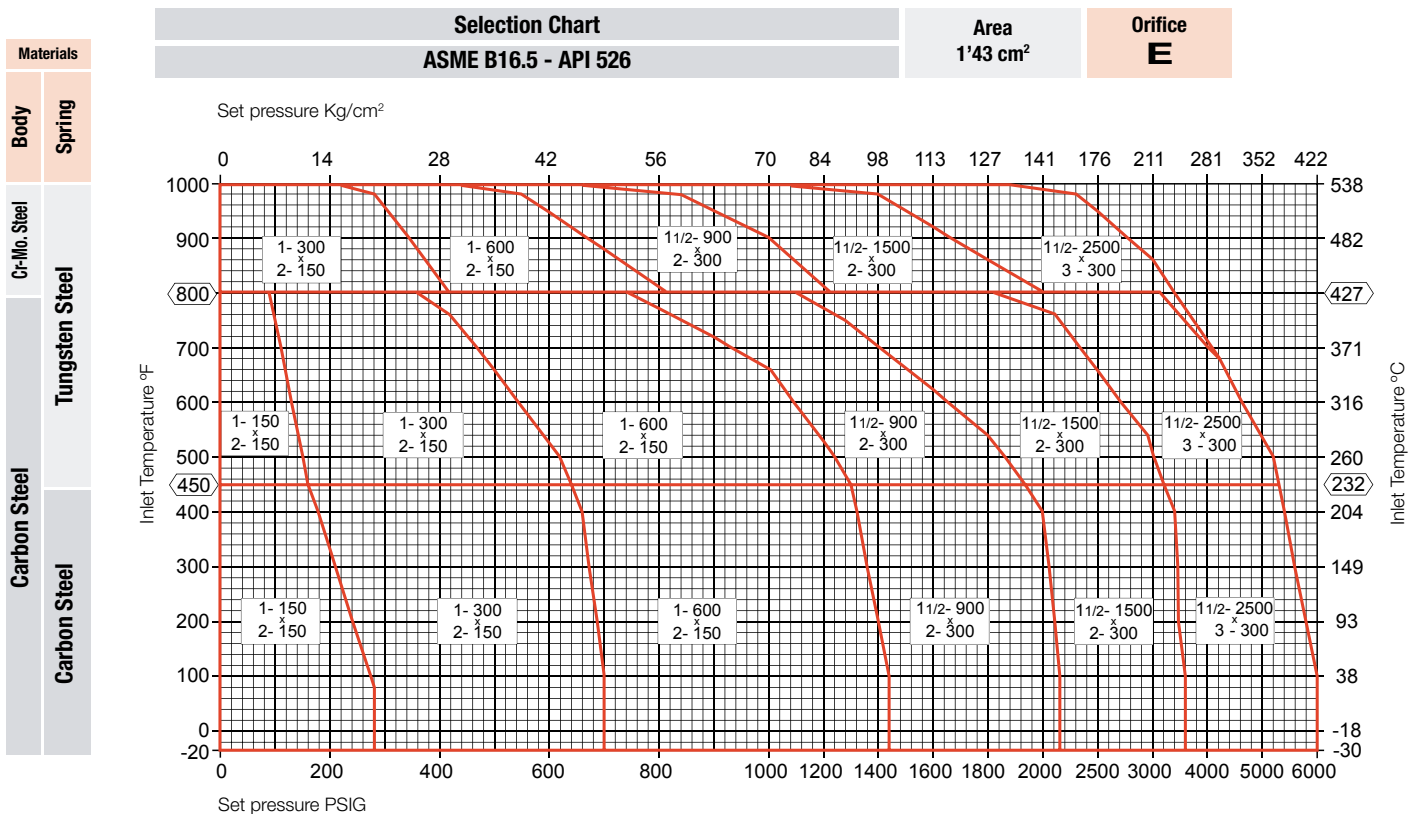
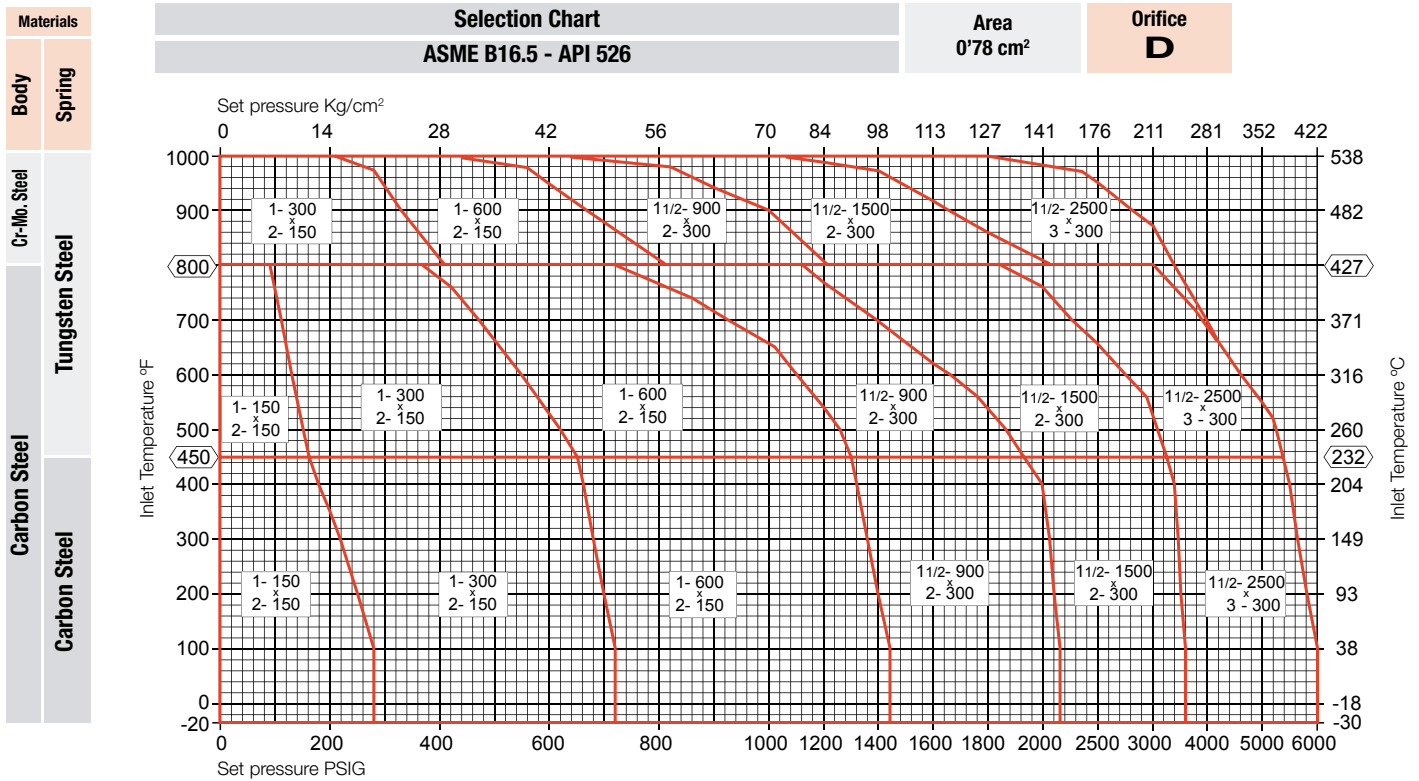



## ■ Technical information / API selection chart

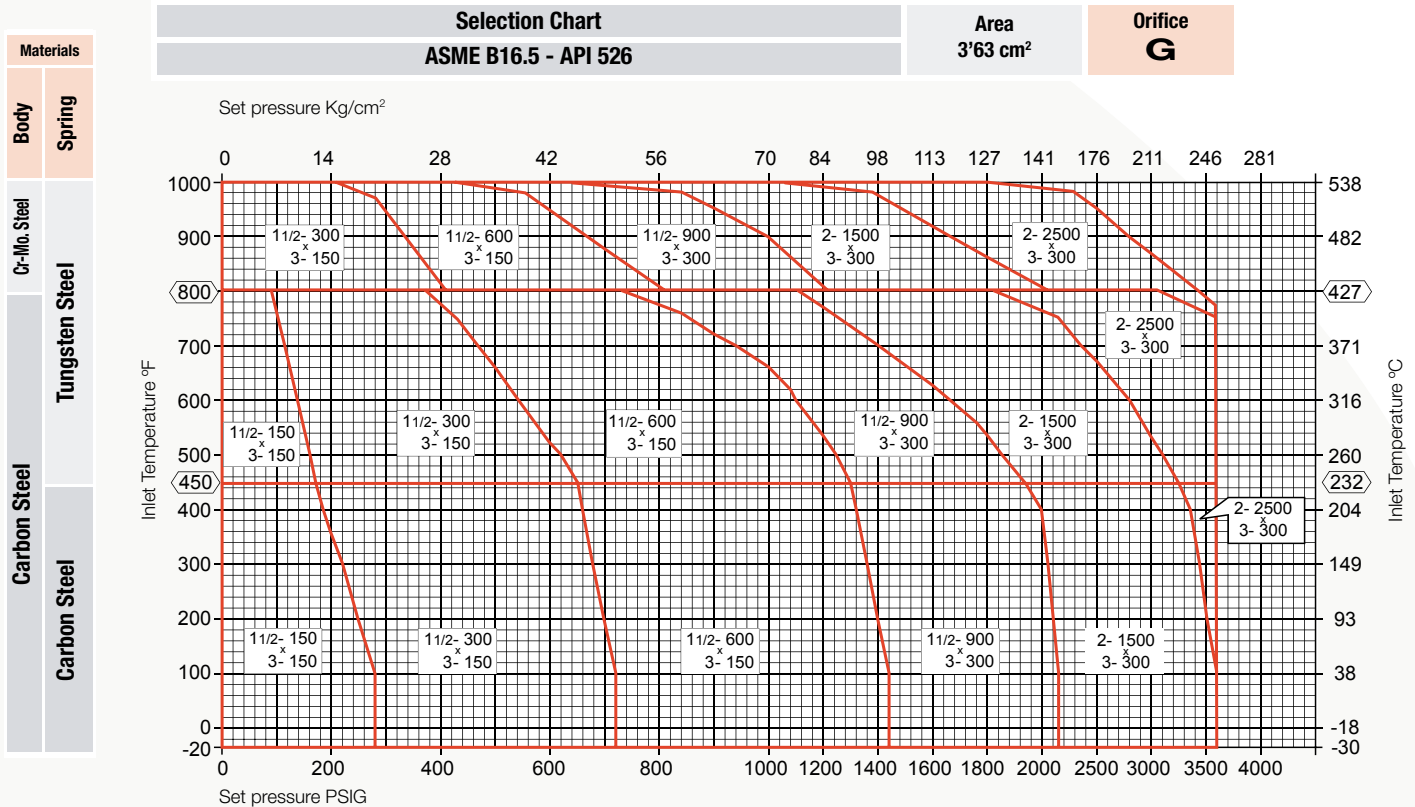
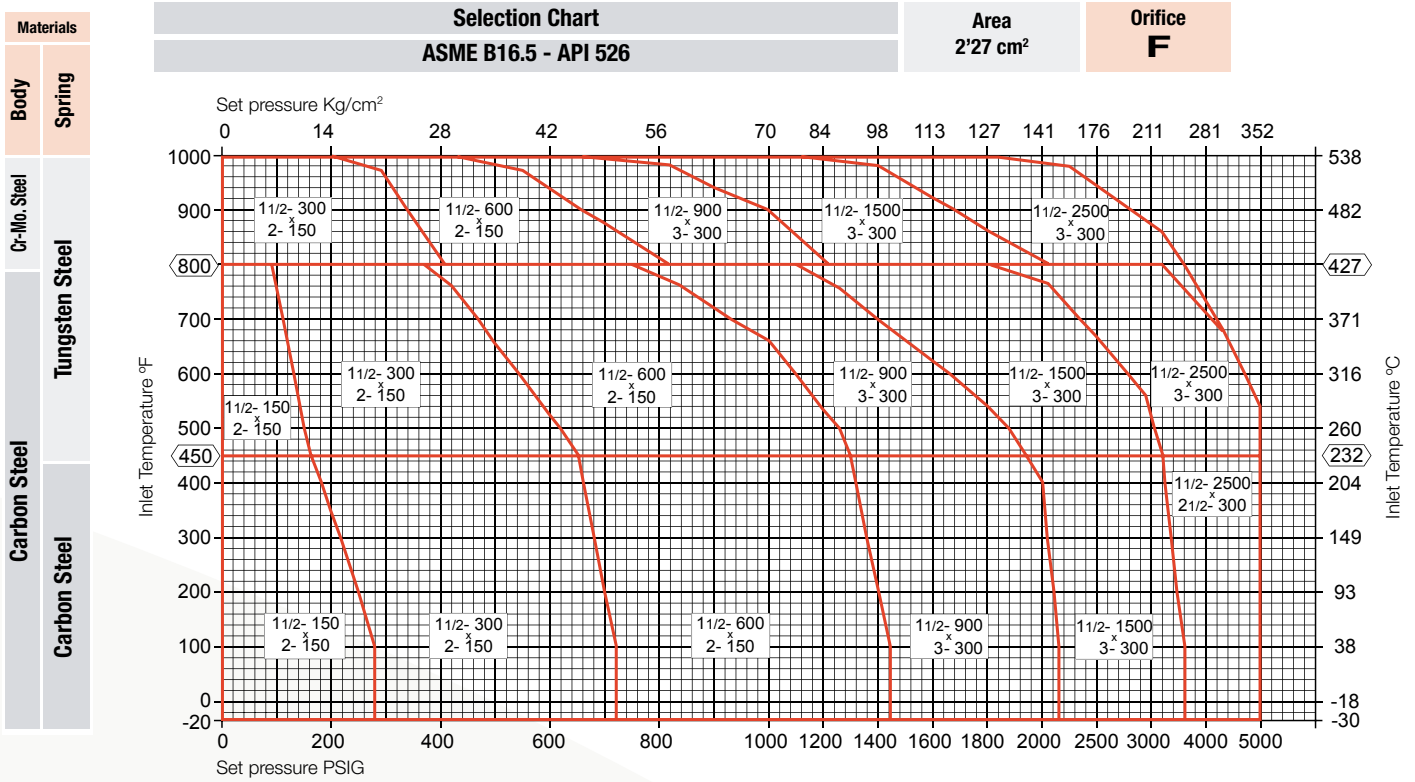



# Technical information / API selection chart

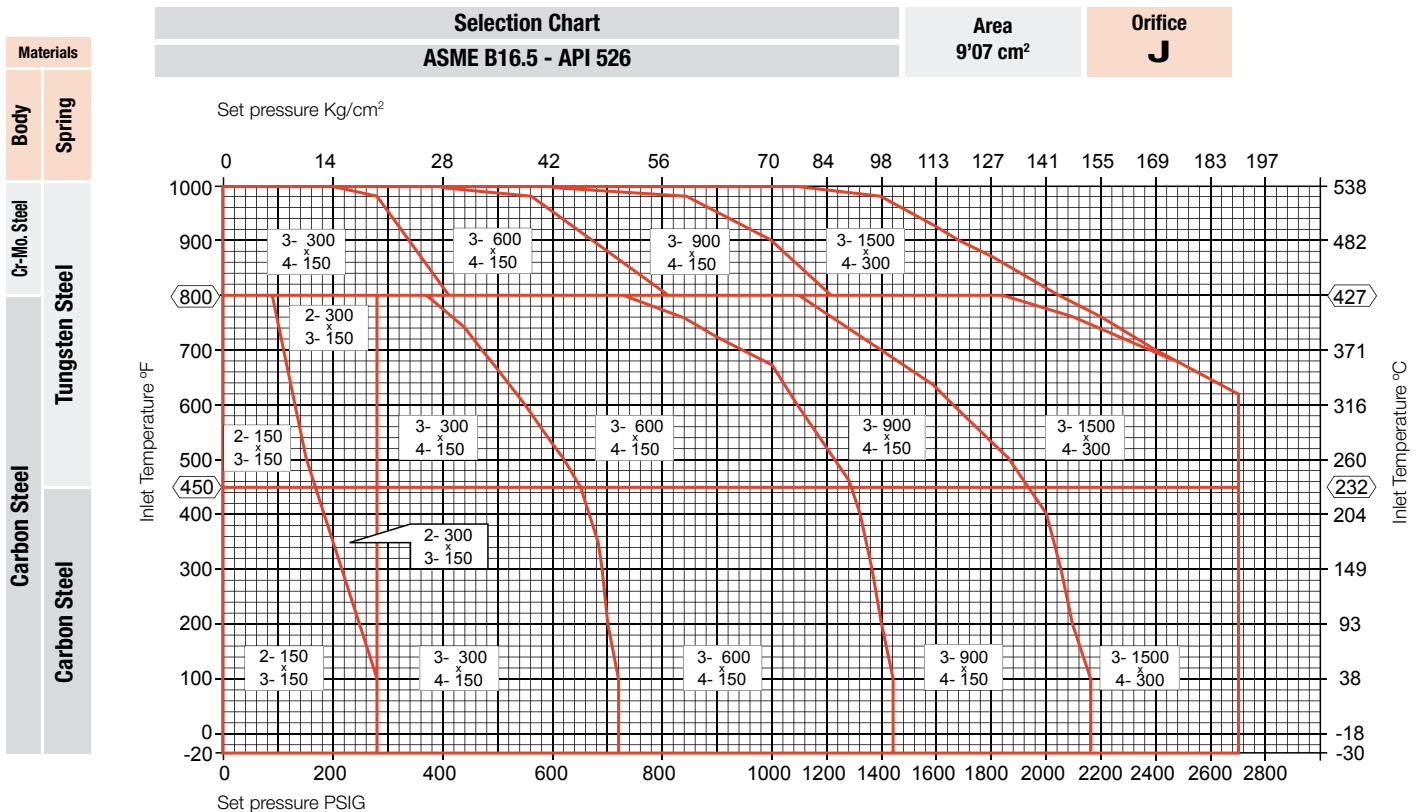
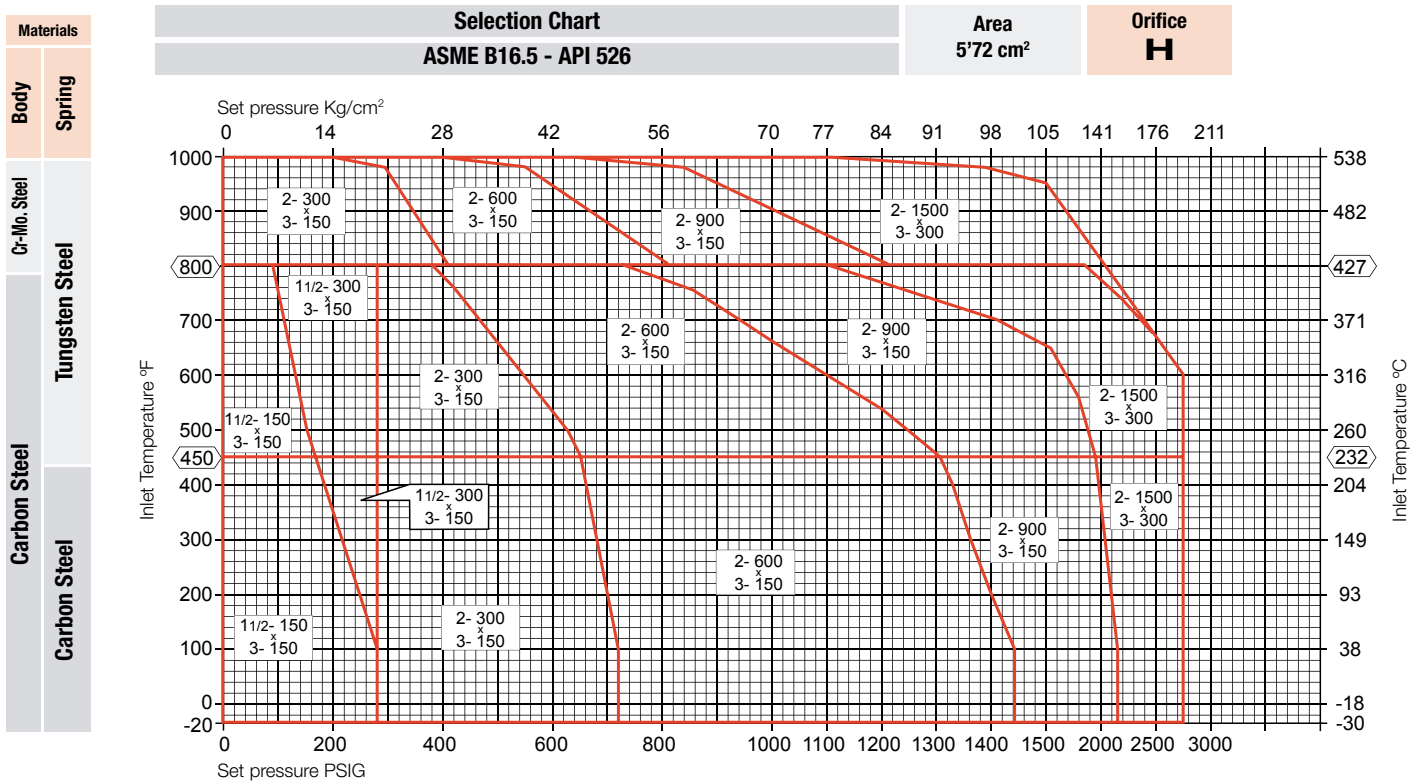





## ■ Technical information / API selection chart

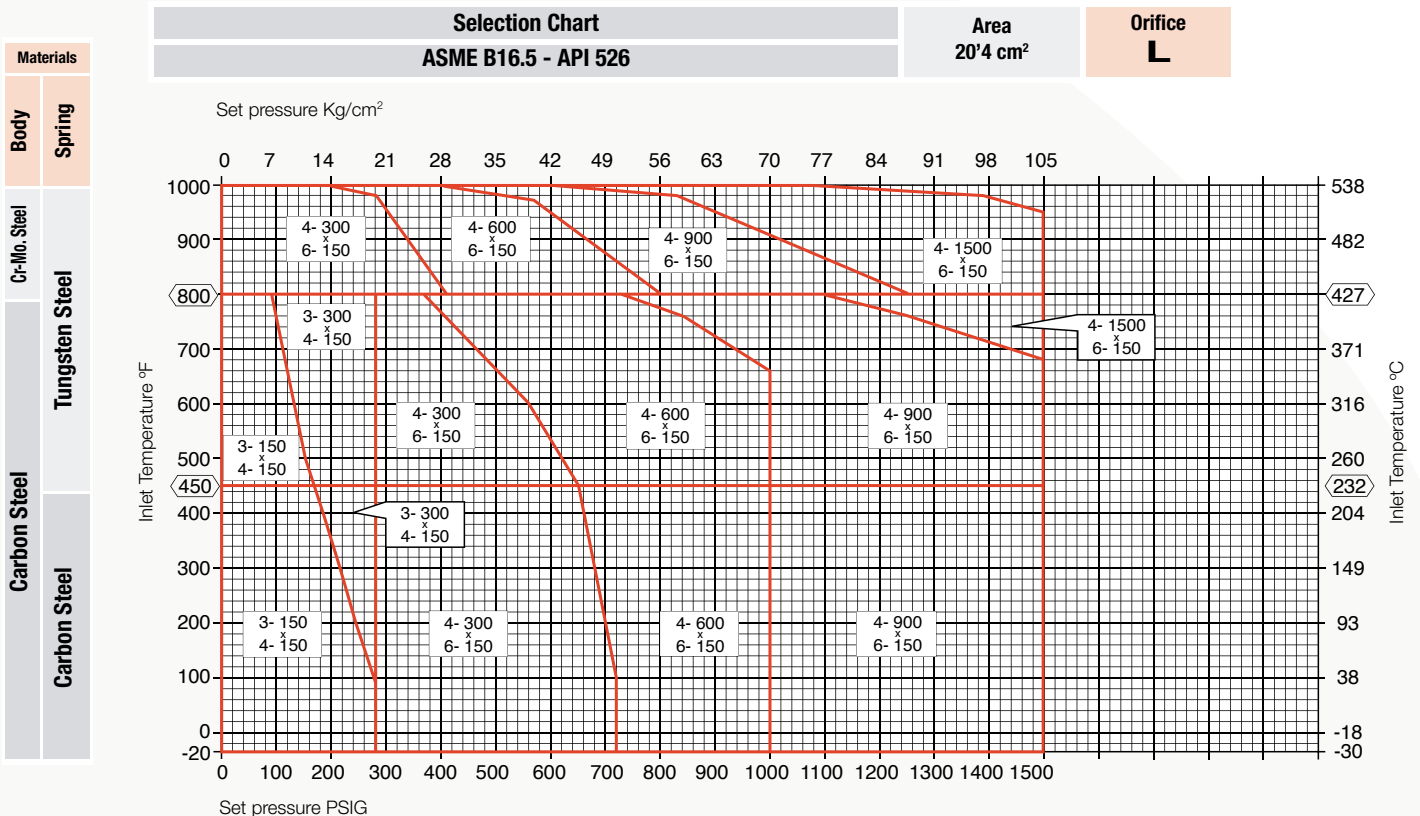
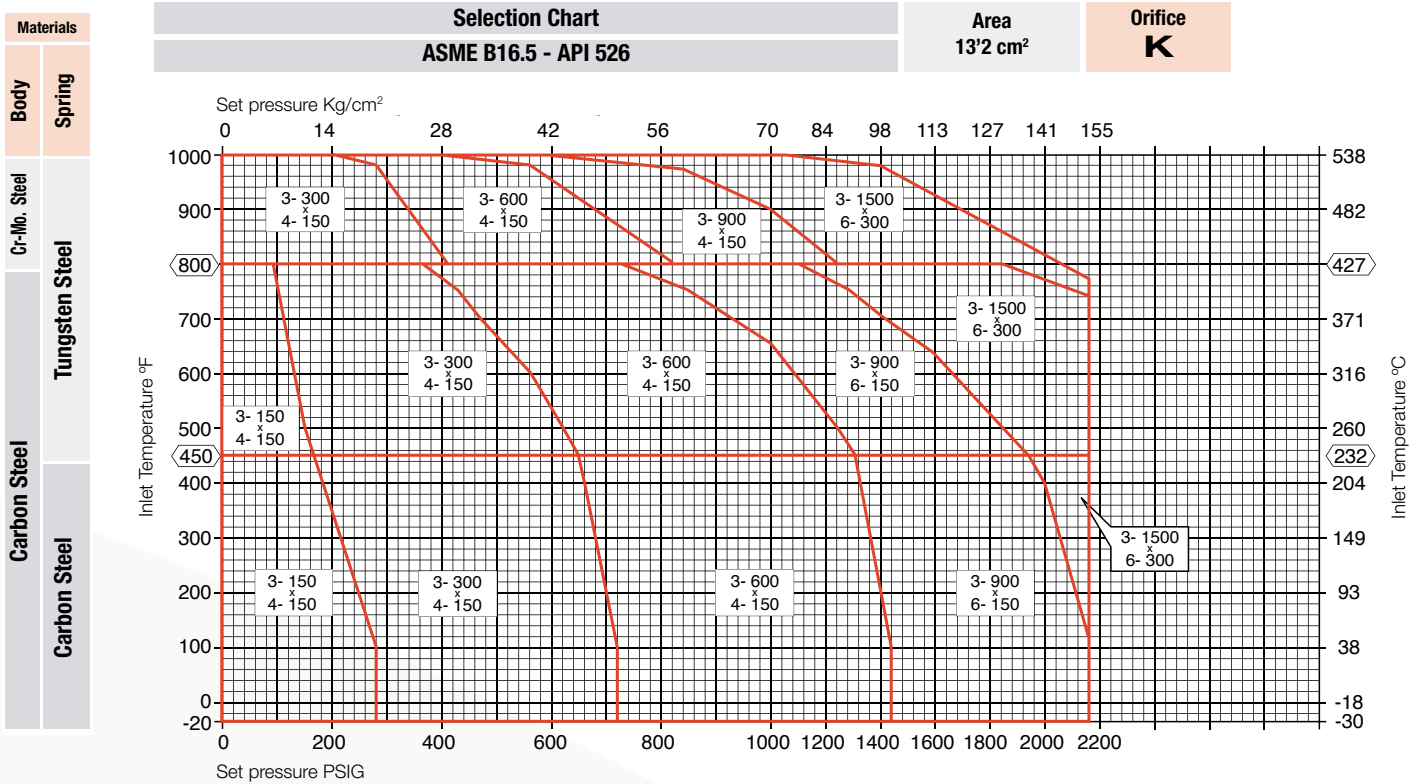

## ■ Technical information / API selection chart

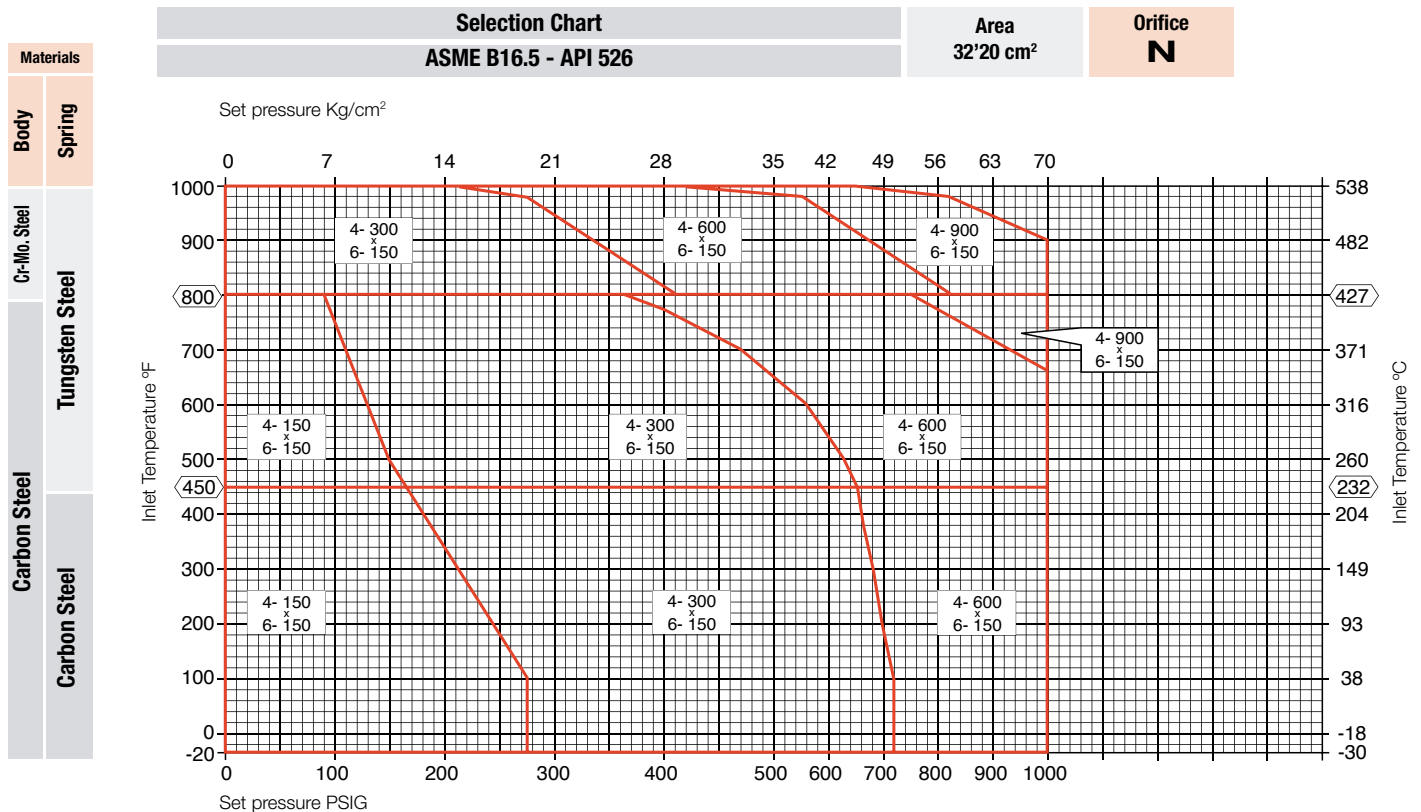
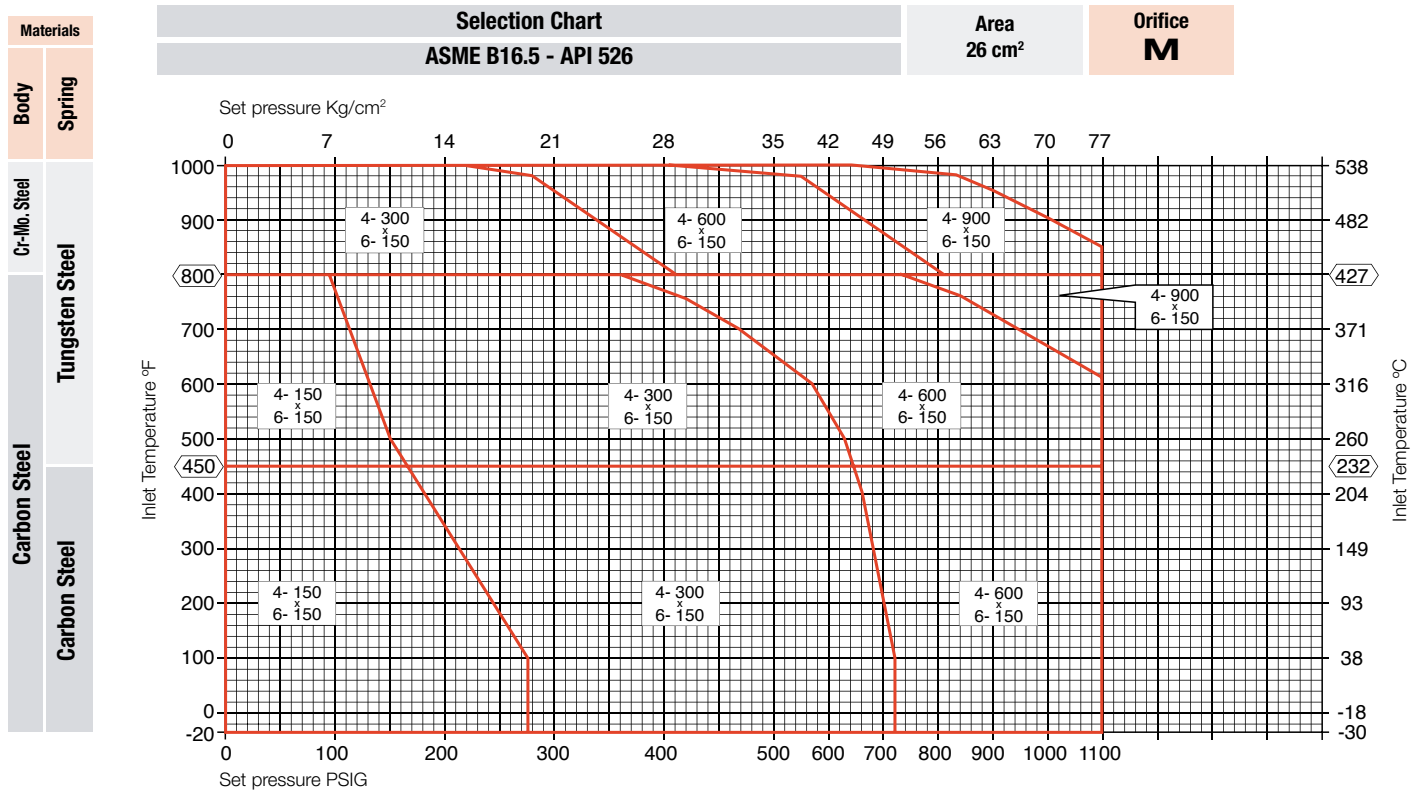



## ■ Technical information / API selection chart

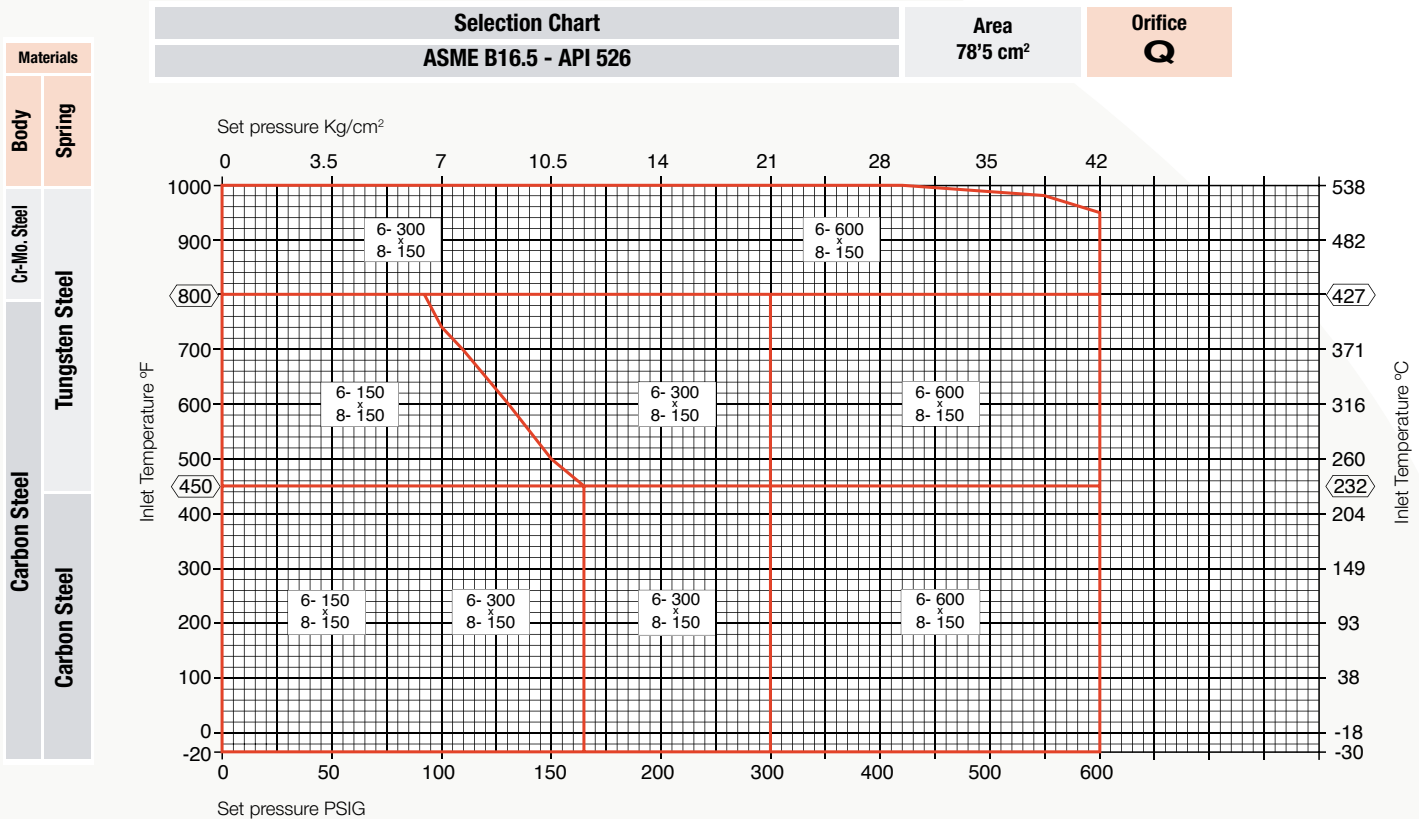
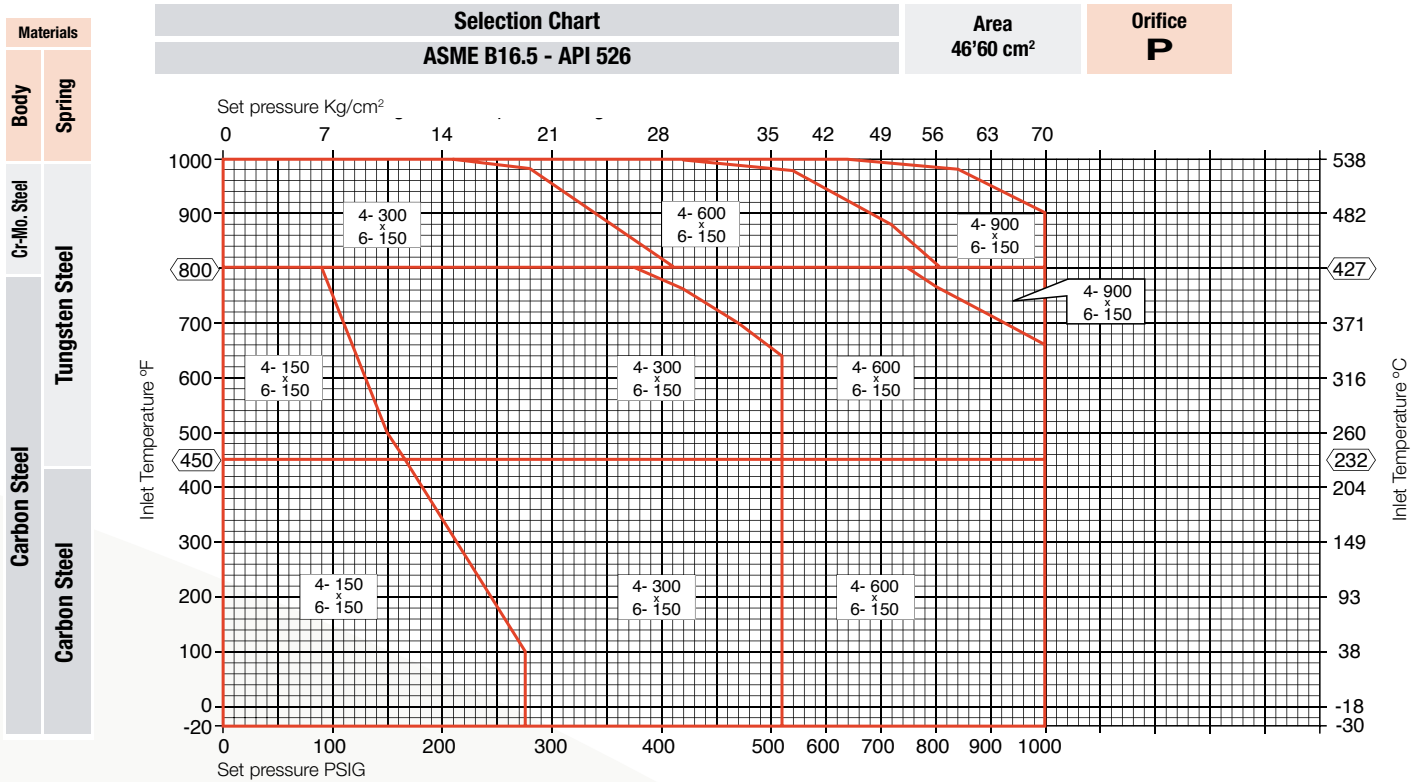



# ■ Technical information / API selection chart

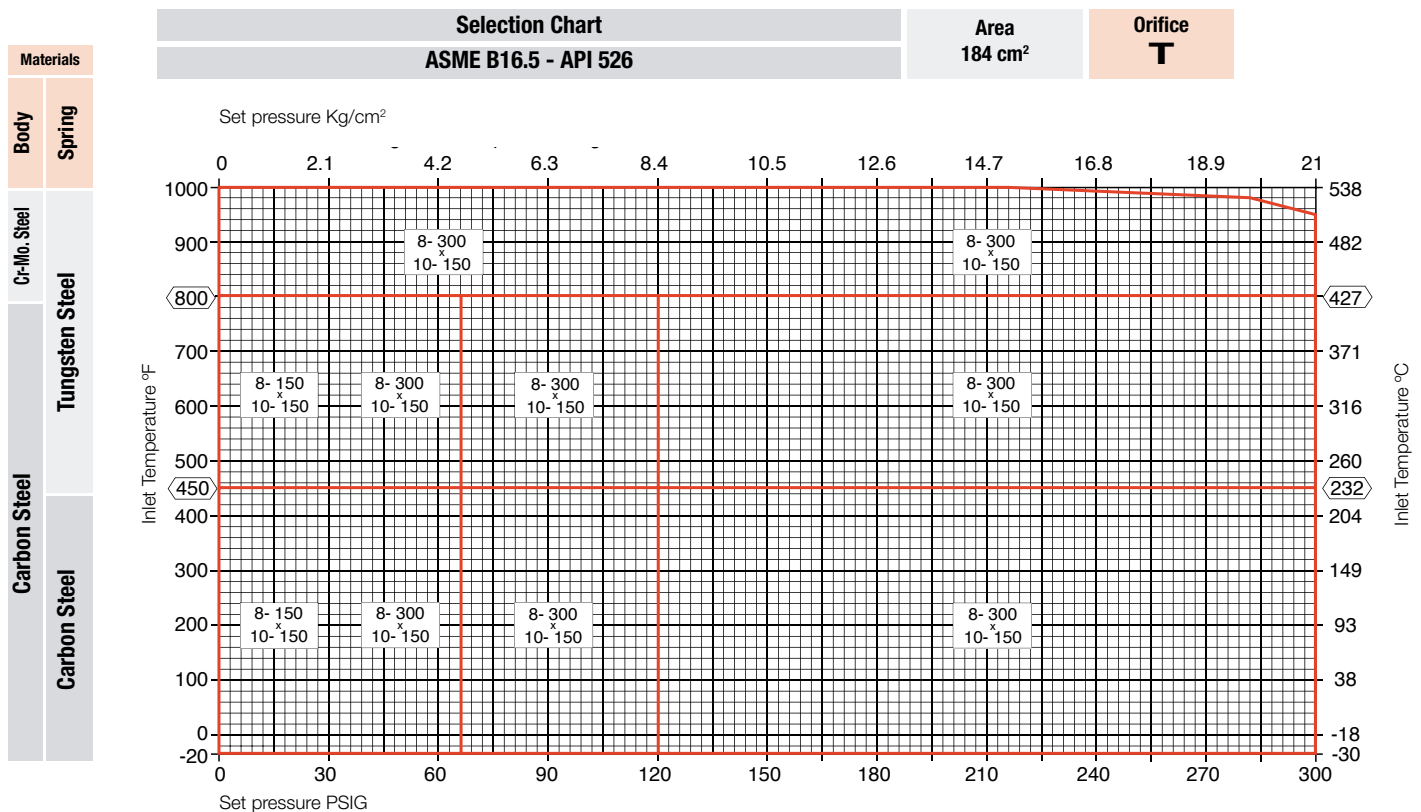
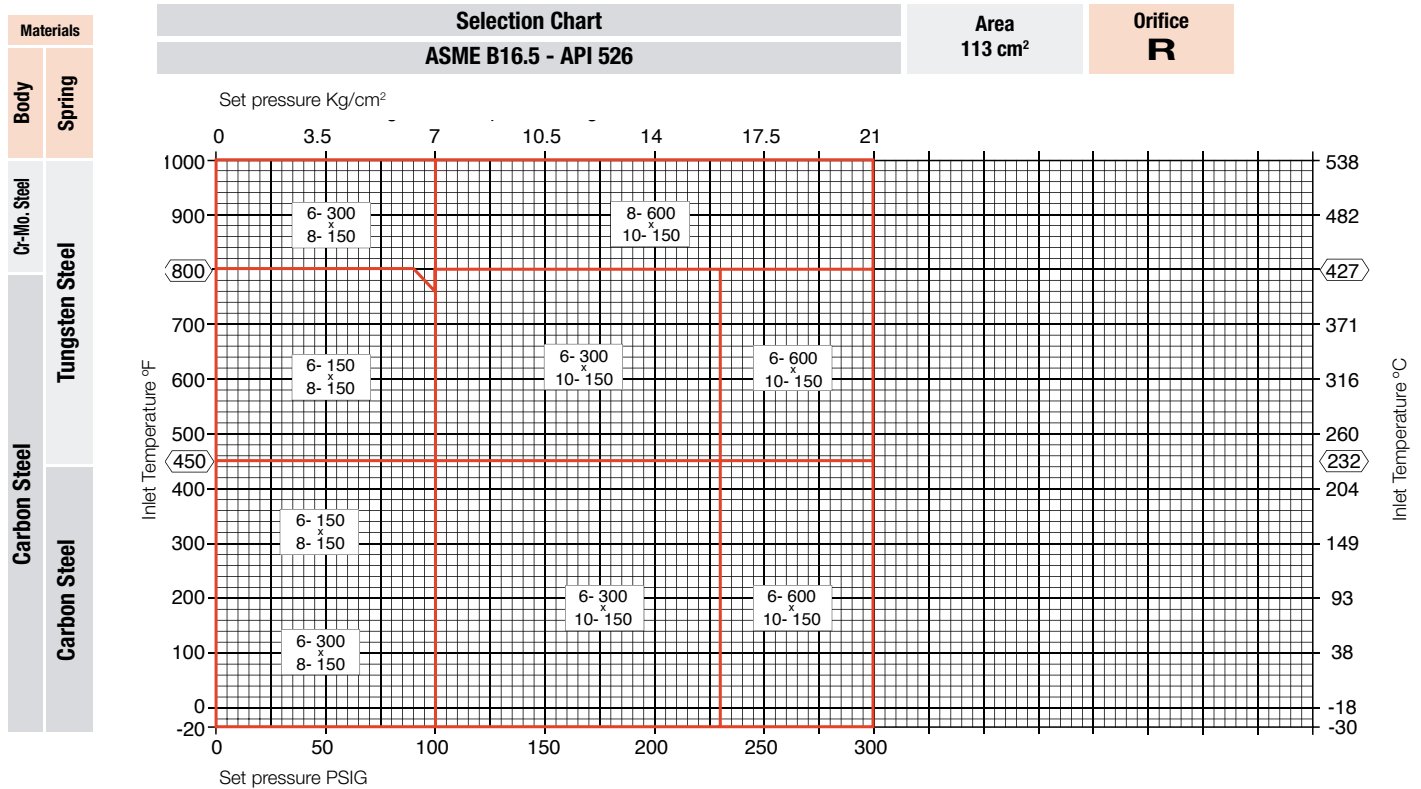

■ **Technical information** / Reaction forces during discharge

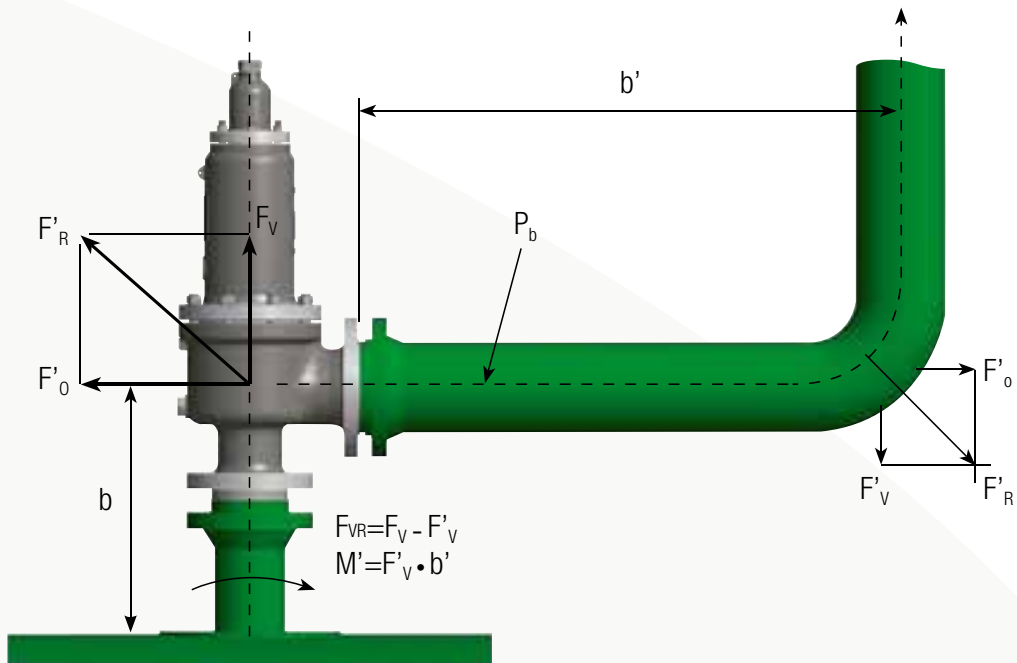
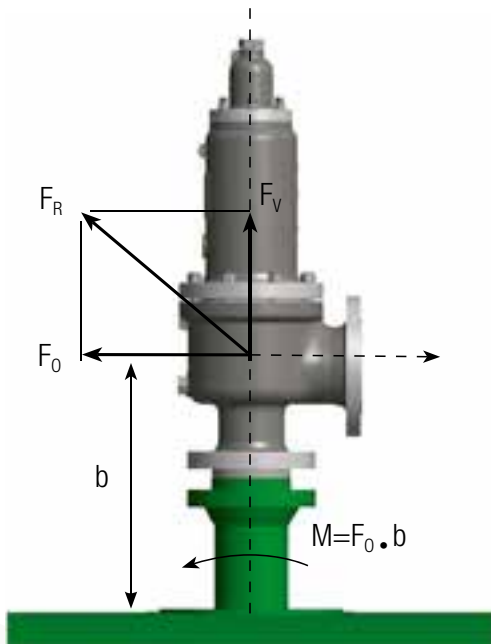

$$F_o = \frac{W}{27,8} \sqrt{\frac{k}{k+1} \cdot \frac{T_1}{M}}$$

For practical use:

$$F_o = 0,1 \cdot W \sqrt{\frac{P_1}{\rho}}$$

$$F_v = 10 \cdot P_1 \cdot A_1 + \frac{W \cdot v_1}{3600}$$

$$F'_o = F_o + 10 \cdot P_b \cdot A_2$$

$$F'_v \cong F_o$$

- $A_1$  (cm<sup>2</sup>) = Inlet pipe area
- $A_2$  (cm<sup>2</sup>) = Outlet pipe area
- $M$  = Molecular weight
- $P_1$  (bar) = Inlet pressure during valve discharge
- $P_b$  (bar) = Back pressure
- $T_1$  (°K) = Inlet temperature
- $v_1$  (m/s) = Inlet average fluid velocity
- $W$  (kg/h) = Discharge flow
- $k$  ( $c_p/c_{v,3}$ ) = Specific heat ratio
- $\rho$  (kg/m<sup>3</sup>) = Specific mass of inlet fluid
- $F$  (N) = Reaction forces



■ **Technical information** / Noise discharge calculation

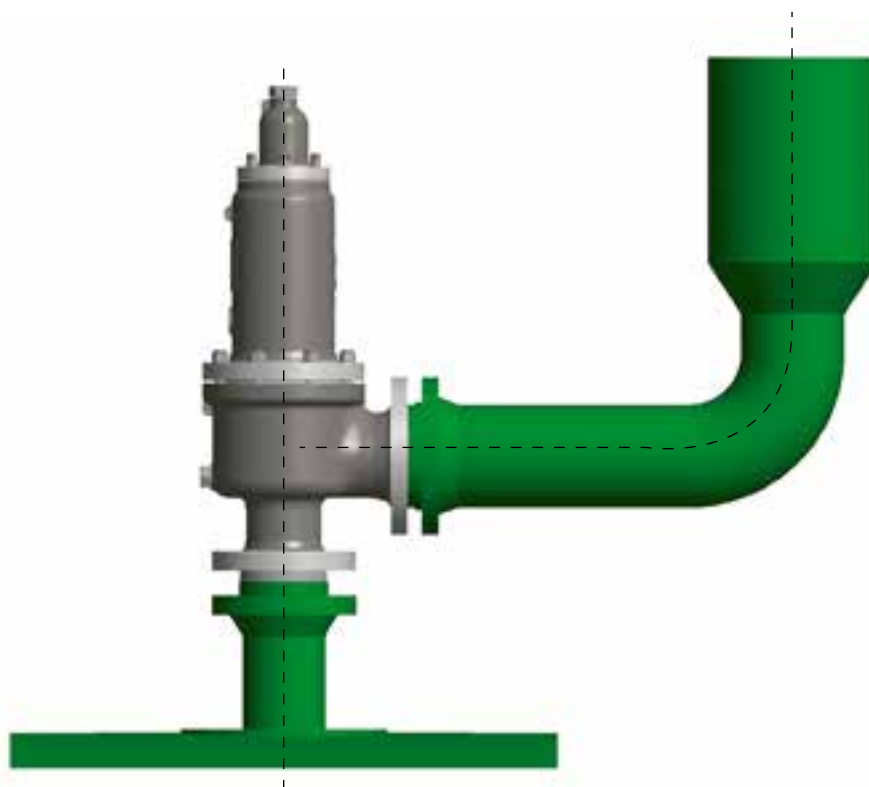

$$L_p \text{ a } 1 \text{ m} = 86 + 10 \cdot \log_{10} \frac{W \cdot K \cdot T}{M}$$

For distances higher than 1 m, use the following formulas:

$$L_{pL} = L_{p1} - 20 \log_{10} L + 3$$

When the discharge is fairly near to the soil.

$$L_{pL} = L_{p1} - 20 \log_{10} L$$

When the discharge is high over the soil.

$L_p$  = Noise level (db)

$W$  = Discharge flow (kg/h)

$k$  = Specific heat ratio (cp/cv)

$T$  = Discharge temperature (°K)

$M$  = Molecular weight

$L$  = Distance between measuring and discharge point. (m)



## ■ Definitions (ASME PTC 25)

**Actual discharge area:** The measured minimum net area that determines the flow through a valve.

**Coefficient of discharge:** The ratio of the measured relieving capacity to the theoretical relieving capacity.

**Conventional direct spring-loaded PRV:** A direct spring-loaded pressure relief valve whose operational characteristics are directly affected by changes in the back pressure.

**Back pressure:** The static pressure existing at the outlet of a pressure relief device due to pressure in the discharge system.

**Balanced direct spring-loaded PRV:** A direct spring-loaded pressure relief valve that incorporates means of minimizing the effect of back pressure on the operational characteristics (opening pressure, closing pressure, and relieving capacity).

**Blowdown:** The difference between actual popping pressure of a pressure relief valve and actual reseating pressure expressed as a percentage of set pressure or in pressure units.

**Blowdown pressure:** The value of decreasing inlet static pressure at which no further discharge is detected at the outlet of a pressure relief valve after the valve has been subjected to a pressure equal to or above the popping pressure.

**Bore area:** The minimum cross-sectional flow area of a nozzle.

**Bore diameter:** The minimum diameter of a nozzle.

**Built-up back pressure:** Pressure existing at the outlet of a pressure relief device caused by the flow through that particular device into a discharge system.

**Cold differential test pressure:** The inlet static pressure at which a pressure relief valve is adjusted to open on the test stand.

This test pressure includes corrections for service conditions of superimposed back pressure and/or temperature.

**Constant back pressure:** A superimposed back pressure that is constant with time.

**Developed lift:** The actual travel of the disk from closed positions to the position reached when the valve is at flow-rating pressure.

**Effective discharge area:** A nominal or computed area of flow through a pressure relief valve, differing from the actual discharge area, for use in recognized flow formulas to determine the capacity of a pressure relief valve.

**Effective seat area:** A computed area for use in calculating the set pressure of a given pressure relief valve when tested using an auxiliary lift-assist device.

**Flow path:** The three-dimensional and geometric characteristics of a device that affects the measured relieving capacity. It is defined from the cross section of the inlet to the cross section of the outlet, including all streamlines in the flow.

**Inlet size:** The nominal pipe size of the inlet of a pressure relief valve, unless otherwise designated.

**Leak test pressure:** The specified inlet static pressure at which a quantitative seat leakage test is performed in accordance with a standard procedure.

**Lift:** The actual travel of the disk away from the closed position when a valve is relieving.

**Maximum allowable pressure:** The maximum pressure for which the equipment is designed as specified by the manufacturer.

**Outlet size:** The nominal pipe size of the outlet of a pressure relief valve, unless otherwise designated.

**Overpressure:** A pressure increase over the set pressure of a pressure relief valve, usually expressed as a percentage of set pressure.

**Popping pressure:** The value of increasing inlet static pressure at which the disk moves in the opening direction at a faster rate as compared with corresponding movement at higher or lower pressure.

**Pressure:** The pressure unit used in this standard is the bar ( $1 \text{ bar} = 10^5 \text{ Pa}$ ). It is quoted as gauge (relative to atmospheric pressure) or absolute as appropriate.

**Pressure Relief Valve (PRV):** A pressure relief device designed to actuate on inlet static pressure and reclose after normal conditions have been restored.

**Re-seating pressure:** The value of decreasing inlet static pressure at which the valve disk re-establishes contact with the seat or at which lift becomes zero.

**Relieving pressure:** Set pressure plus overpressure

**Safety valve:** A pressure relief valve characterized by rapid opening and normally used to relieve compressible fluids.

**Set pressure:** The value of increasing inlet static pressure at which a pressure relief device displays one of the operational characteristics as defined under opening pressure, popping pressure, start-to-leak pressure, burst pressure, or breaking pressure. (The applicable operating characteristic for a specific device design is specified by the device manufacturer).

**Safety relief valve:** A pressure relief valve characterized by rapid opening or by gradual opening that is generally proportional to the increase in pressure. It can be used for compressible or incompressible fluids.

**Superimposed back pressure:** The static pressure existing at the outlet of a pressure relief device at the time the device is required to operate. It is the result of pressure in the discharge system from other sources.

### Safety valve main components:

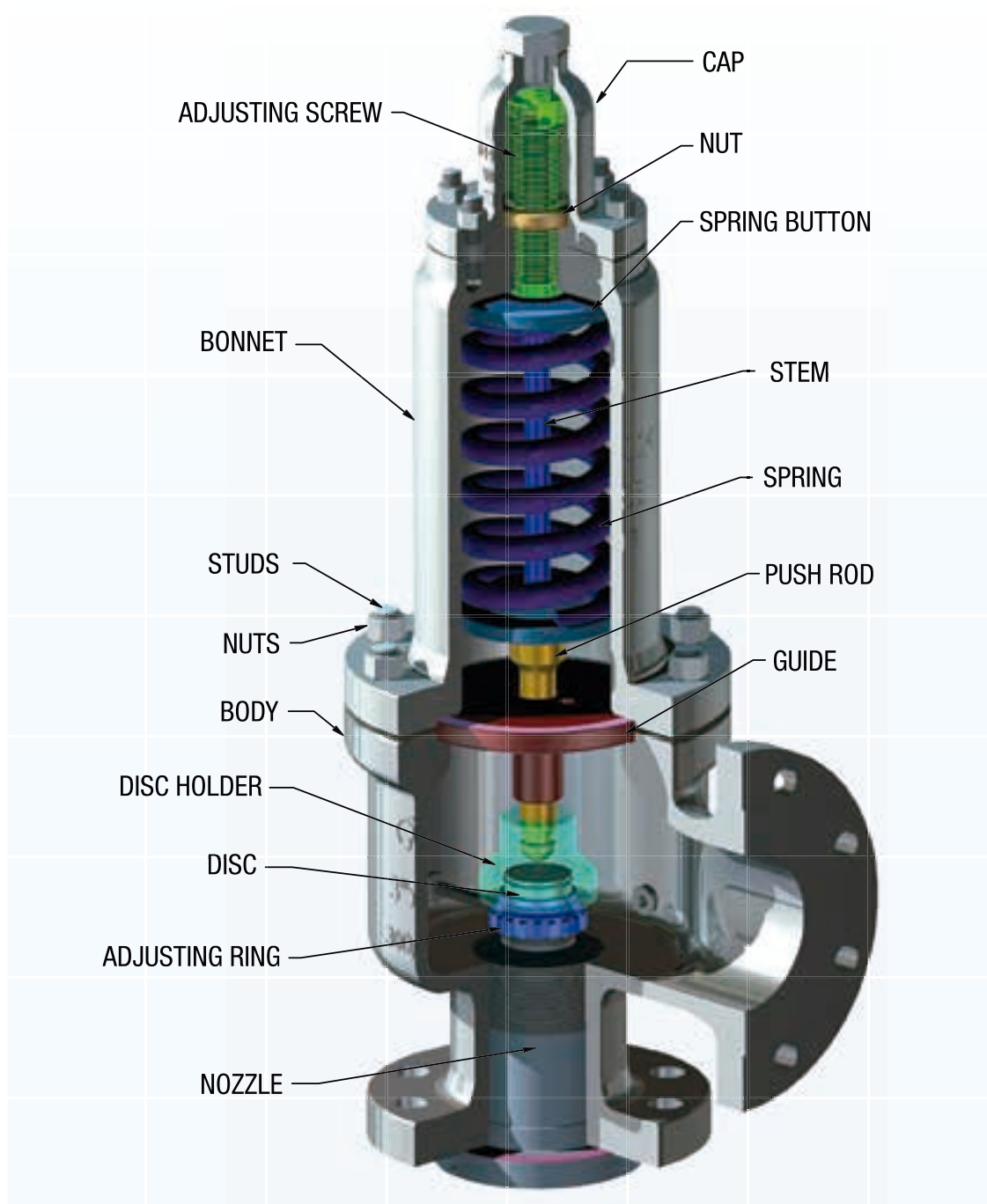



C/ Chopín, 2 - 4 - Pol. Ind Can Jardí  
08191 Rubí (Barcelona) Spain  
Tel.: +34 936 995 200  
Fax: +34 936 974 556  
[safety@valvulasnacional.com](mailto:safety@valvulasnacional.com)  
[www.valvulasnacional.com](http://www.valvulasnacional.com)

Member of Pecos group

